

RE.E3

Vulcanised rubber wheels

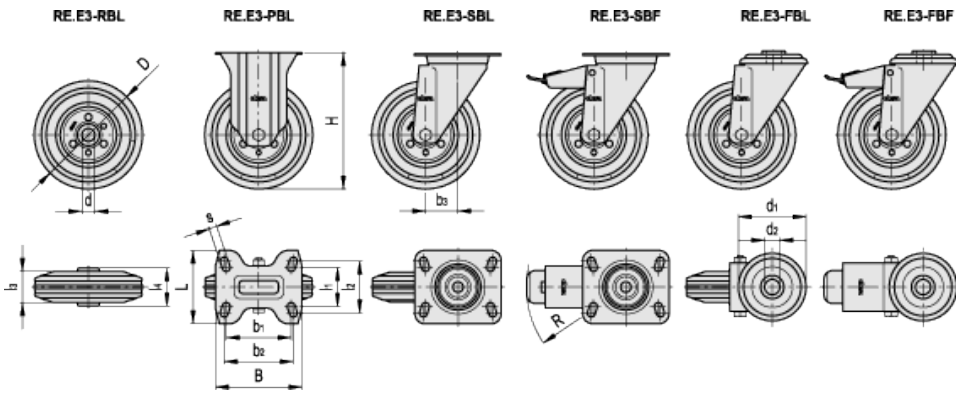

Elesa Standards		Main dimensions																Static load *	Rolling resistance	Dynamic carrying capacity	Weight
Code	Description	D	d	I ₃	I ₄	H	B	L	s	b ₁	I ₁	b ₂	I ₂	b ₃	R	d ₁	d ₂	[N]	[N]	[N]	g
450001	RE.E3-080-RBL	80	12	25	39	-	-	-	-	-	-	-	-	-	-	-	-	2600	600	650	170
450006	RE.E3-100-RBL	100	12	30	44	-	-	-	-	-	-	-	-	-	-	-	-	3000	750	800	280
450012	RE.E3-125-RBL	125	15	37.5	44	-	-	-	-	-	-	-	-	-	-	-	-	3300	850	1300	510
450016	RE.E3-150-RBL	150	15	40	44	-	-	-	-	-	-	-	-	-	-	-	-	3500	1000	1700	730
450022	RE.E3-200-RBL	200	20	50	58	-	-	-	-	-	-	-	-	-	-	-	-	4100	1400	2300	1750
450151	RE.E3-080-PBL	80	12	25	-	107	100	85	9	75	45	80	60	-	-	-	-	-	600	650	490
450156	RE.E3-100-PBL	100	12	30	-	128	100	85	9	75	45	80	60	-	-	-	-	-	750	800	620
450161	RE.E3-125-PBL	125	15	37.5	-	156	100	85	9	75	45	80	60	-	-	-	-	-	850	1300	920
450166	RE.E3-150-PBL	150	15	40	-	182	100	85	9	75	45	80	60	-	-	-	-	-	1000	1700	1220
450171	RE.E3-200-PBL	200	20	50	-	240	140	114	11	105	73	105	85	-	-	-	-	-	1400	2300	2890
450051	RE.E3-080-SBL	80	12	25	-	107	100	85	9	75	45	80	60	39	-	-	-	-	600	650	690
450056	RE.E3-100-SBL	100	12	30	-	128	100	85	9	75	45	80	60	35	-	-	-	-	750	800	820
450061	RE.E3-125-SBL	125	15	37.5	-	156	100	85	9	75	45	80	60	37	-	-	-	-	850	1300	1180
450066	RE.E3-150-SBL	150	15	40	-	182	100	85	9	75	45	80	60	37	-	-	-	-	1000	1700	1400
450071	RE.E3-200-SBL	200	20	50	-	240	140	110	11	105	73	105	87	56	-	-	-	-	1400	2300	3250
450101	RE.E3-080-SBF	80	12	25	-	107	100	85	9	75	45	80	60	39	120	-	-	-	600	650	870
450106	RE.E3-100-SBF	100	12	30	-	128	100	85	9	75	45	80	60	35	120	-	-	-	750	800	1000

Elesa Standards		Main dimensions																Static load *	Rolling resistance	Dynamic carrying capacity	Weight
Code	Description	D	d	I ₃	I ₄	H	B	L	s	b ₁	l ₁	b ₂	l ₂	b ₃	R	d ₁	d ₂	[N]	[N]	[N]	g
450111	RE.E3-125-SBF	125	15	37.5	-	156	100	85	9	75	45	80	60	37	120	-	-	-	850	1300	1300
450116	RE.E3-150-SBF	150	15	40	-	182	100	85	9	75	45	80	60	37	120	-	-	-	1000	1700	1570
450121	RE.E3-200-SBF	200	20	50	-	240	140	110	11	105	73	105	87	56	156	-	-	-	1400	2300	3390
450201	RE.E3-080-FBL	80	12	25	-	107	-	-	-	-	-	-	-	39	-	73	12	-	600	650	610
450206	RE.E3-100-FBL	100	12	30	-	128	-	-	-	-	-	-	-	35	-	73	12	-	750	800	740
450211	RE.E3-125-FBL	125	15	37.5	-	156	-	-	-	-	-	-	-	37	-	73	12	-	850	1300	1090
450216	RE.E3-150-FBL	150	15	40	-	182	-	-	-	-	-	-	-	37	-	73	12	-	1000	1700	1350
450221	RE.E3-200-FBL	200	20	50	-	236	-	-	-	-	-	-	-	56	-	102	20	-	1400	2300	3160
450251	RE.E3-080-FBF	80	12	25	-	107	-	-	-	-	-	-	-	39	120	73	12	-	600	650	780
450256	RE.E3-100-FBF	100	12	30	-	128	-	-	-	-	-	-	-	35	120	73	12	-	750	800	940
450261	RE.E3-125-FBF	125	15	37.5	-	156	-	-	-	-	-	-	-	37	120	73	12	-	850	1300	1240
450266	RE.E3-150-FBF	150	15	40	-	182	-	-	-	-	-	-	-	37	120	73	12	-	1000	1700	1490
450271	RE.E3-200-FBF	200	20	50	-	236	-	-	-	-	-	-	-	56	156	102	20	-	1400	2300	3290

* The static load value is characteristic of the wheel only without motion

Covering with tread

Vulcanised rubber NBR; hardness 83 Shore A.

Wheel centre body

Consisting of two zinc-plated and riveted plate disks.

Bore

Polyamide-based technopolymer (PA) plain bearings, resistant to solvents, oils and other chemicals, integral to the centre.

Axle set

Calibrated zinc-plated steel precision tube. The tube serves as a spacer, is tightened to the bracket with screw and nut to a un predetermined torque value.

The wheel bore rotates onto the tube freely.

Standard executions (bore with plain bearing)

- RBL: wheel only.
- PBL: brakeless wheel and zinc-plated steel fixed plate bracket.
- SBL: brakeless wheel and zinc-plated steel turning plate bracket.
- SBF: wheel with brake and zinc-plated steel turning plate bracket.
- FBL: brakeless wheel and zinc-plated steel turning plate bracket with central pass-through hole.
- FBF: wheel with brake and zinc-plated steel turning plate bracket with central pass-through hole.

Fixed plate bracket

Zinc-plated steel plate, the bracket is designed to withstand loads up to 4000N. The bracket load capacity is greater than the dynamic carrying capacity of the wheel assembly plus the bracket (see table), this is a further safety feature.

Turning plate bracket

Zinc-plated steel plate, the bracket is designed to withstand loads up to 4000N. The bracket load capacity is greater than the dynamic carrying capacity of the wheel assembly plus the bracket (see table), this is a further safety feature.

The presence of two ball turns and the direct contact between the plate and the ball race ring with built-in pin ensure excellent manoeuvrability and very limited clearance (see fig. 1).

Does not require maintenance. It consists of:

- 1) fitting plate: electrolytically zinc-plated steel plate;
- 2) fork: electrolytically zinc-plated steel plate;
- 3) ball race ring: electrolytically zinc-plated steel plate;
- 4) central pin: incorporated in the plate, cold reformed;
- 5) rotation system: dual grease-lubricated ring of ball;
- 6) dust seal: RAL 7015 dark grey technopolymer.

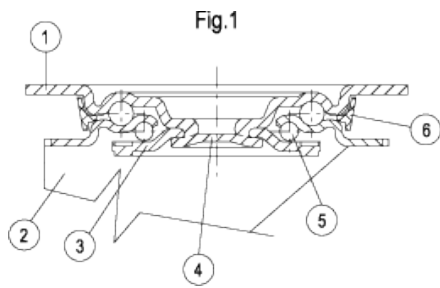

Front-actuated brake

- 80-150mm diameter wheels: total brake that locks the wheel and bracket rotation.

The optimised dimensions and the retractable pedal ensure minimal space occupied and maximum actuation ease.

In order to optimise the wheel lock in both directions of rotation, the spring is fitted with a dual braking tooth. Hardened carbon steel spring.

- 200mm diameter wheel: total brake that locks the wheel and bracket rotation.

The optimised dimensions and the retractable pedal ensure minimal space occupied and maximum actuation ease. Hardened carbon steel spring.

Applications

The wheel RE.E3 may be mounted on different kind of trolleys, with medium-light loads; it is also suitable for outdoor use.

Typical applications: trolleys for industrial moving, for outdoor use also, waste dumpsters.

Environmental conditions

Suitable for use in humid environments and in the presence of atmospheric agents; use in environments with the presence of organic, chlorinated solvents, hydrocarbons and mineral oils is not recommended.

Rolling resistance - force / load applied

The diagram shows the force to be applied to a wheel to keep it moving at the constant speed of 4 km/h, according to the applied load.

The intersection point with a 50N value is the maximum transportable load with a manually actuated 4-wheel trolley; in fact, 200N = 50N x 4 wheels is the maximum force that may be supported by the operator according to the regulations in force regarding work safety.

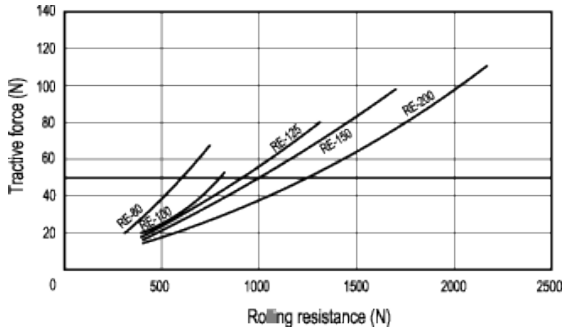





















Mechanical moving with towing devices

For mechanical towing, please see the technical specifications to determine the capacity variation.

Temperature

If operating temperatures in an application differ from the standard range of values, please see the technical specifications to determine the capacity variation.

- Recommended
- Tolerated
- ▲ Not recommended

Selection parameters	Value range		
Load capacity		Light load, up to 250 kg	●
		Medium load, up to 750 kg	▲
		Heavy load, more than 750 kg	▲
Rolling resistance		< 125 kg	●
		> 125 kg	▲
Flooring		Tiles	●
		Asphalt	●
		Cement - resin	●
		Not paved	●
		Expanded metal	●
		With chips, obstacles, etc.	▲
Environmental chemical conditions		No aggressive chemicals	●
		With aggressive chemicals	▲
Temperature		-40° / -20°	□
		-20° / +80°	●
		+80° / +120°	▲
		> 120°	▲
Means of traction		Manual (speed ≤ 4 Km/h)	●
		Mechanical (speed ≤ 16 Km/h)	▲
		Mechanical (speed > 16 Km/h)	▲



STANDARD MACHINE ELEMENTS WORLDWIDE

ELESA models all rights reserved in accordance with the law. Always mention the source when reproducing our drawings.