

# RE.G1

Thermoplastic rubber wheels

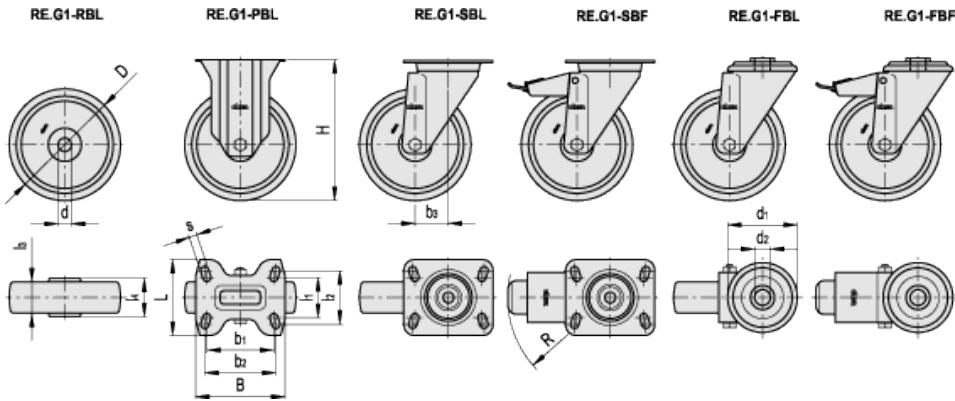

Elesa Standards		Main dimensions														Static load *	Rolling resistance	Dynamic carrying capacity	Weight		
Code	Description	D	d	I <sub>3</sub>	I <sub>4</sub>	H	B	L	s	b <sub>1</sub>	I <sub>1</sub>	b <sub>2</sub>	I <sub>2</sub>	b <sub>3</sub>	R	d <sub>1</sub>	d <sub>2</sub>	[N]	[N]	[N]	g
452501	RE.G1-080-RBL	80	12	30	39	-	-	-	-	-	-	-	-	-	-	-	-	1000	700	700	90
452506	RE.G1-100-RBL	100	12	30	44	-	-	-	-	-	-	-	-	-	-	-	-	1500	1000	1000	120
452511	RE.G1-125-RBL	125	15	35	44	-	-	-	-	-	-	-	-	-	-	-	-	1800	1200	1200	200
452516	RE.G1-150-RBL	150	20	45	59	-	-	-	-	-	-	-	-	-	-	-	-	2700	1800	1800	360
452651	RE.G1-080-PBL	80	12	30	-	107	100	85	9	75	45	80	60	-	-	-	-	-	700	700	360
452656	RE.G1-100-PBL	100	12	30	-	128	100	85	9	75	45	80	60	-	-	-	-	-	1000	1000	390
452661	RE.G1-125-PBL	125	15	35	-	156	100	85	9	75	45	80	60	-	-	-	-	-	1200	1200	610
452666	RE.G1-150-PBL	150	20	45	-	194	140	114	11	105	73	105	85	-	-	-	-	-	1800	1800	1350
452551	RE.G1-080-SBL	80	12	30	-	107	100	85	9	75	45	80	60	39	-	-	-	-	700	700	600
452556	RE.G1-100-SBL	100	12	30	-	128	100	85	9	75	45	80	60	35	-	-	-	-	1000	1000	700
452561	RE.G1-125-SBL	125	15	35	-	156	100	85	9	75	45	80	60	37	-	-	-	-	1200	1200	860
452566	RE.G1-150-SBL	150	20	45	-	194	140	110	11	105	73	105	87	56	-	-	-	-	1800	1800	1720
452601	RE.G1-080-SBF	80	12	30	-	107	100	85	9	75	45	80	60	39	120	-	-	-	700	700	790
452606	RE.G1-100-SBF	100	12	30	-	128	100	85	9	75	45	80	60	35	120	-	-	-	1000	1000	850
452611	RE.G1-125-SBF	125	15	35	-	156	100	85	9	75	45	80	60	37	120	-	-	-	1200	1200	1000
452616	RE.G1-150-SBF	150	20	45	-	194	140	110	11	105	73	105	87	56	156	-	-	-	1800	1800	2000

Elesa Standards		Main dimensions														Static load *	Rolling resistance	Dynamic carrying capacity	Weight		
Code	Description	D	d	l <sub>3</sub>	l <sub>4</sub>	H	B	L	s	b <sub>1</sub>	l <sub>1</sub>	b <sub>2</sub>	l <sub>2</sub>	b <sub>3</sub>	R	d <sub>1</sub>	d <sub>2</sub>	[N]	[N]	[N]	g
452701	RE.G1-080-FBL	80	12	30	-	107	-	-	-	-	-	-	-	39	-	73	12	-	700	700	530
452706	RE.G1-100-FBL	100	12	30	-	128	-	-	-	-	-	-	-	35	-	73	12	-	1000	1000	630
452711	RE.G1-125-FBL	125	15	35	-	156	-	-	-	-	-	-	-	37	-	73	12	-	1200	1200	800
452716	RE.G1-150-FBL	150	20	45	-	188	-	-	-	-	-	-	-	56	-	102	20	-	1800	1800	1580
452751	RE.G1-080-FBF	80	12	30	-	107	-	-	-	-	-	-	-	39	120	73	12	-	700	700	710
452756	RE.G1-100-FBF	100	12	30	-	128	-	-	-	-	-	-	-	35	120	73	12	-	1000	1000	840
452761	RE.G1-125-FBF	125	15	35	-	156	-	-	-	-	-	-	-	37	120	73	12	-	1200	1200	950
452766	RE.G1-150-FBF	150	20	45	-	188	-	-	-	-	-	-	-	56	156	102	20	-	1800	1800	1870

\* The static load value is characteristic of the wheel only without motion

### Covering

Grey anti-trace thermoplastic wheel, hardness 85 Shore A.

### Wheel centre body

Polypropylene-based technopolymer (PP). Resistant to solvents, oils and other chemicals.

### Bore

Directly made into the centre.

### Axle set

Calibrated zinc-plated steel precision tube. The tube serves as a spacer, is tightened to the bracket with screw and nut to a un predetermined torque value.

The wheel bore rotates onto the tube freely.

### Standard executions

- RBL: wheel only.
- PBL: brakeless wheel and zinc-plated steel fixed plate bracket.
- SBL: brakeless wheel and zinc-plated steel turning plate bracket.
- SBF: wheel with brake and zinc-plated steel turning plate bracket.
- FBL: brakeless wheel and zinc-plated steel turning plate bracket with central pass-through hole.
- FBF: wheel with brake and zinc-plated steel turning plate bracket with central pass-through hole.

### Fixed plate bracket

Zinc-plated steel plate, the bracket is designed to withstand loads up to 4000N. The bracket load capacity is greater than the dynamic carrying capacity of the wheel assembly plus the bracket (see table), this is a further safety feature.

### Turning plate bracket

Zinc-plated steel plate, the bracket is designed to withstand loads up to 4000N. The bracket load capacity is greater than the dynamic carrying capacity of the wheel assembly plus the bracket (see table), this is a further safety feature.

The presence of two ball turns and the direct contact between the plate and the ball race ring with built-in pin ensure excellent manoeuvrability and very limited clearance (see fig. 1).

Does not require maintenance. It consists of:

- 1) fitting plate: electrolytically zinc-plated steel plate;
- 2) fork: electrolytically zinc-plated steel plate;
- 3) ball race ring: electrolytically zinc-plated steel plate;
- 4) central pin: incorporated in the plate, cold reformed;
- 5) rotation system: dual grease-lubricated ring of ball;
- 6) dust seal: RAL 7015 dark grey technopolymer.

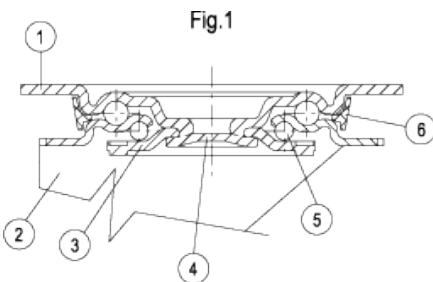

### Front-actuated brake

Total brake that locks the wheel and bracket rotation.

The optimised dimensions and the retractible pedal ensure minimal space occupied and maximum actuation ease.

In order to optimise the wheel lock in both directions of rotation, the spring is fitted with a dual braking tooth. Hardened carbon steel spring.

### Applications

The wheel RE.G1 has excellent smoothness and elasticity features.

### Environmental conditions

The wheel RE.G1 is suitable for use in humid environments and in the presence of medium-aggressive chemicals; use in environments with the presence of organic, chlorinated solvents, hydrocarbons and mineral oils is not recommended.

*Rolling resistance - force / load applied*

The diagram shows the force to be applied to a wheel to keep it moving at the constant speed of 4 km/h, according to the applied load. The intersection point with a 50N value is the maximum transportable load with a manually actuated 4-wheel trolley; in fact, 200N = 50N x 4 wheels is the maximum force that may be supported by the operator according to the regulations in force regarding work safety.

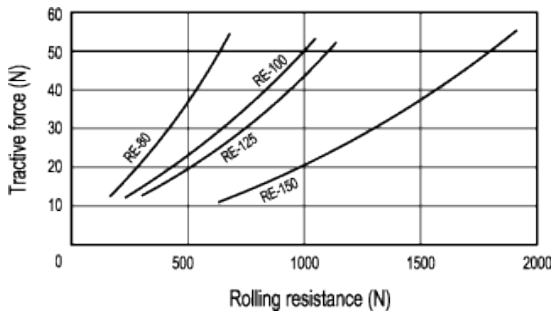





















*Mechanical moving with towing devices*

For mechanical towing, please see the technical specifications to determine the capacity variation.

*Temperature*

If operating temperatures in an application differ from the standard range of values, please see the technical specifications to determine the capacity variation.

- Recommended
- Tolerated
- ▲ Not recommended

Selection parameters	Value range	
<b>Load capacity</b>	 Light load, up to 250 kg	●
	 Medium load, up to 750 kg	▲
	 Heavy load, more than 750 kg	▲
<b>Rolling resistance</b>	 < 125 kg	●
	 > 125 kg	▲
<b>Flooring</b>	 Tiles	●
	 Asphalt	●
	 Cement - resin	●
	 Not paved	▲
	 Expanded metal	●
	 With chips, obstacles, etc.	▲
<b>Environmental chemical conditions</b>	 No aggressive chemicals	●
	 With aggressive chemicals	●
<b>Temperature</b>	 -40° / -20°	▲
	 -20° / +80°	●
	 +80° / +120°	▲
	 > 120°	▲
<b>Means of traction</b>	 Manual (speed ≤ 4 Km/h)	●
	 Mechanical (speed ≤ 16 Km/h)	▲
	 Mechanical (speed > 16 Km/h)	▲





ELESA models all rights reserved in accordance with the law. Always mention the source when reproducing our drawings.