

# RE.FF

Injected polyurethane wheels

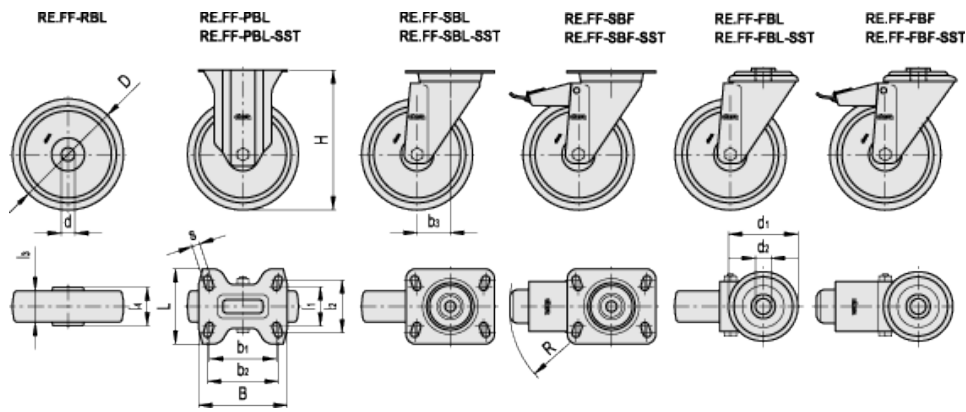

INOX  
Stainless Steel



Elesa Standards		Main dimensions														Static load *	Rolling resistance	Dynamic carrying capacity	Weight		
Code	Description	D	d	l <sub>3</sub>	l <sub>4</sub>	H	B	L	s	b <sub>1</sub>	l <sub>1</sub>	b <sub>2</sub>	l <sub>2</sub>	b <sub>3</sub>	R	d <sub>1</sub>	d <sub>2</sub>	[N]	[N]	[N]	g
451001	RE.FF-080-RBL	80	12	30	39	-	-	-	-	-	-	-	-	-	-	-	-	2200	1200	1200	110
451006	RE.FF-100-RBL	100	12	30	44	-	-	-	-	-	-	-	-	-	-	-	-	3000	1700	1700	150
451011	RE.FF-125-RBL	125	15	35	44	-	-	-	-	-	-	-	-	-	-	-	-	3500	2300	2300	250
451016	RE.FF-150-RBL	150	20	45	59	-	-	-	-	-	-	-	-	-	-	-	-	5000	2800	3500	470
451151	RE.FF-080-PBL	80	12	30	-	107	100	85	9	75	45	80	60	-	-	-	-	-	1200	1200	380
451156	RE.FF-100-PBL	100	12	30	-	128	100	85	9	75	45	80	60	-	-	-	-	-	1700	1700	430
451161	RE.FF-125-PBL	125	15	35	-	156	100	85	9	75	45	80	60	-	-	-	-	-	2300	2200	660
451166	RE.FF-150-PBL	150	20	45	-	194	140	114	11	105	73	105	85	-	-	-	-	-	2800	3000	1460
451051	RE.FF-080-SBL	80	12	30	-	107	100	85	9	75	45	80	60	39	-	-	-	-	1200	1200	620
451056	RE.FF-100-SBL	100	12	30	-	128	100	85	9	75	45	80	60	35	-	-	-	-	1700	1700	740
451061	RE.FF-125-SBL	125	15	35	-	156	100	85	9	75	45	80	60	37	-	-	-	-	2300	2200	910
451066	RE.FF-150-SBL	150	20	45	-	194	140	110	11	105	73	105	87	56	-	-	-	-	2800	3000	1830
451101	RE.FF-080-SBF	80	12	30	-	107	100	85	9	75	45	80	60	39	120	-	-	-	1200	1200	810
451106	RE.FF-100-SBF	100	12	30	-	128	100	85	9	75	45	80	60	35	120	-	-	-	1700	1700	890
451111	RE.FF-125-SBF	125	15	35	-	156	100	85	9	75	45	80	60	37	120	-	-	-	2300	2200	1050
451116	RE.FF-150-SBF	150	20	45	-	194	140	110	11	105	73	105	87	56	156	-	-	-	2800	3000	2110

Elesa Standards		Main dimensions														Static load *	Rolling resistance	Dynamic carrying capacity	Weight			
Code	Description	D	d	l <sub>3</sub>	l <sub>4</sub>	H	B	L	s	b <sub>1</sub>	l <sub>1</sub>	b <sub>2</sub>	l <sub>2</sub>	b <sub>3</sub>	R	d <sub>1</sub>	d <sub>2</sub>	[N]	[N]	[N]	g	
451171	RE.FF-80-FBL	80	12	30	-	107	-	-	-	-	-	-	-	-	39	-	73	12	-	1200	1200	550
451173	RE.FF-100-FBL	100	12	30	-	128	-	-	-	-	-	-	-	-	35	-	73	12	-	1700	1700	670
451176	RE.FF-125-FBL	125	15	35	-	156	-	-	-	-	-	-	-	-	37	-	73	12	-	2300	2200	850
451179	RE.FF-150-FBL	150	20	45	-	188	-	-	-	-	-	-	-	-	56	-	102	20	-	2800	3000	1690
451181	RE.FF-80-FBF	80	12	30	-	107	-	-	-	-	-	-	-	-	39	120	73	12	-	1200	1200	730
451183	RE.FF-100-FBF	100	12	30	-	128	-	-	-	-	-	-	-	-	35	120	73	12	-	1700	1700	880
451186	RE.FF-125-FBF	125	15	35	-	156	-	-	-	-	-	-	-	-	37	120	73	12	-	2300	2200	1000
451189	RE.FF-150-FBF	150	20	45	-	188	-	-	-	-	-	-	-	-	56	156	102	20	-	2800	3000	1980

\* The static load value is characteristic of the wheel only without motion

Elesa Standards		Main dimensions														Rolling resistance	Dynamic carrying capacity	Weight			
Code	Description	D	d	l <sub>3</sub>	H	B	L	s	b <sub>1</sub>	l <sub>1</sub>	b <sub>2</sub>	l <sub>2</sub>	b <sub>3</sub>	R	d <sub>1</sub>	d <sub>2</sub>	[N]	[N]	g		
451301	RE.FF-080-PBL-SST	80	12	30	107	100	85	9	75	45	80	60	-	-	-	-	-	-	1200	1200	350
451306	RE.FF-100-PBL-SST	100	12	30	128	100	85	9	75	45	80	60	-	-	-	-	-	-	1700	1700	400
451311	RE.FF-125-PBL-SST	125	15	35	156	100	85	9	75	45	80	60	-	-	-	-	-	-	2300	2200	640
451201	RE.FF-080-SBL-SST	80	12	30	107	100	85	9	75	45	80	60	39	-	-	-	-	-	1200	1200	610
451206	RE.FF-100-SBL-SST	100	12	30	128	100	85	9	75	45	80	60	35	-	-	-	-	-	1700	1700	650
451211	RE.FF-125-SBL-SST	125	15	35	156	100	85	9	75	45	80	60	37	-	-	-	-	-	2300	2200	810
451251	RE.FF-080-SBF-SST	80	12	30	107	100	85	9	75	45	80	60	39	120	-	-	-	-	1200	1200	780
451256	RE.FF-100-SBF-SST	100	12	30	128	100	85	9	75	45	80	60	35	120	-	-	-	-	1700	1700	830
451261	RE.FF-125-SBF-SST	125	15	35	156	100	85	9	75	45	80	60	37	120	-	-	-	-	2300	2200	950
451351	RE.FF-080-FBL-SST	80	12	30	107	-	-	-	-	-	-	-	-	39	-	73	12	-	1200	1200	550
451353	RE.FF-100-FBL-SST	100	12	30	128	-	-	-	-	-	-	-	-	35	-	73	12	-	1700	1700	670
451356	RE.FF-125-FBL-SST	125	15	35	156	-	-	-	-	-	-	-	-	37	-	73	12	-	2300	2200	850
451361	RE.FF-080-FBF-SST	80	12	30	107	-	-	-	-	-	-	-	-	39	120	73	12	-	1200	1200	550
451363	RE.FF-100-FBF-SST	100	12	30	128	-	-	-	-	-	-	-	-	35	120	73	12	-	1700	1700	770
451366	RE.FF-125-FBF-SST	125	15	35	156	-	-	-	-	-	-	-	-	37	120	73	12	-	2300	2200	860

#### Covering

Injected polyurethan, hardness 55 Shore D.

#### Wheel centre body

Polyamide-based technopolymer (PA). Resistant to solvents, oils and other chemicals.

#### Bore

Directly made into the centre.

#### Axle set

Calibrated precision tube. The tube serves as a spacer, is tightened to the bracket with screw and nut to a un predetermined torque value. The wheel bore rotates onto the tube freely.

#### Standard executions

- RBL: wheel only.
- PBL: brakeless wheel and zinc-plated steel fixed plate bracket.
- SBL: brakeless wheel and zinc-plated steel turning plate bracket.
- SBF: wheel with brake and zinc-plated steel turning plate bracket.
- FBL: brakeless wheel and zinc-plated steel turning plate bracket with central pass-through hole.
- FBF: wheel with brake and zinc-plated steel turning plate bracket with central pass-through hole.
- PBL-SST: brakeless wheel and stainless steel fixed plate bracket.
- SBL-SST: brakeless wheel and stainless steel turning plate bracket.
- SBF-SST: wheel with brake and stainless steel turning plate bracket.
- FBL-SST: brakeless wheel and stainless steel turning plate bracket with central pass-through hole.
- FBF-SST: wheel with brake and stainless steel turning plate bracket with central pass-through hole.

#### Fixed plate bracket

Zinc-plated steel or stainless steel (SST version) plate, the bracket is designed to withstand loads up to 4000N. The bracket load capacity is greater than the dynamic carrying capacity of the wheel assembly plus the bracket (see table), this is a further safety feature.

#### Turning plate bracket

Zinc-plated steel or stainless steel (SST version) plate, the bracket is designed to withstand loads up to 4000N. The bracket load capacity is greater than the dynamic carrying capacity of the wheel assembly plus the bracket (see table), this is a further safety feature. The presence of two ball turns and the direct contact between the plate and the ball race ring with built-in pin ensure excellent manoeuvrability

and very limited clearance (see fig. 1).

Does not require maintenance. It consists of:

- 1) fitting plate: electrolytically zinc-plated steel plate;
- 2) fork: electrolytically zinc-plated steel plate;
- 3) ball race ring: electrolytically zinc-plated steel plate;
- 4) central pin: incorporated in the plate, cold reflanged;
- 5) rotation system: dual grease-lubricated ring of ball;
- 6) dust seal: RAL 7015 dark grey technopolymer.

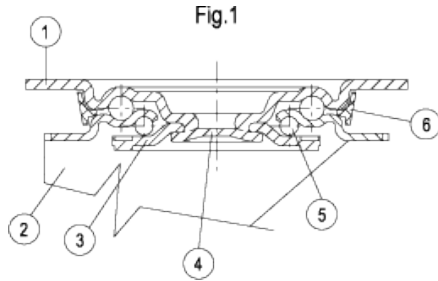

#### Front-actuated brake

Total brake that locks the wheel and bracket rotation.

The optimised dimensions and the retractible pedal ensure minimal space occupied and maximum actuation ease.

In order to optimise the wheel lock in both directions of rotation, the spring is fitted with a dual braking tooth. Hardened carbon steel or stainless steel (SST version) spring.

#### Applications

Excellent smoothness and elasticity features, good wear and tearing resistance.

#### Environmental conditions

Suitable for use in environments with the presence of atmospheric agents, alcohols and glycols; weak organic and mineral acids, water and saturated vapour.

#### Rolling resistance - force / load applied

The diagram shows the force to be applied to a wheel to keep it moving at the constant speed of 4 km/h, according to the applied load.

The intersection point with a 50N value is the maximum transportable load with a manually actuated 4-wheel trolley; in fact, 200N = 50N x 4 wheels is the maximum force that may be supported by the operator according to the regulations in force regarding work safety.

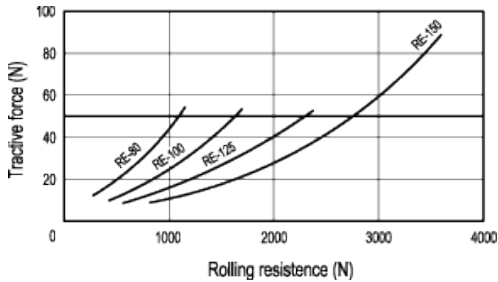





















#### Mechanical moving with towing devices

For mechanical towing, please see the technical specifications to determine the capacity variation.

#### Temperature

If operating temperatures in an application differ from the standard range of values, please see the technical specifications to determine the capacity variation.

- Recommended
- Tolerated
- ▲ Not recommended

Selection parameters	Value range		
<b>Load capacity</b>		Light load, up to 250 kg	●
		Medium load, up to 750 kg	●
		Heavy load, more than 750 kg	□
<b>Rolling resistance</b>		< 125 kg	●
		> 125 kg	□
<b>Flooring</b>		Tiles	●
		Asphalt	●
		Cement - resin	●
		Not paved	▲
		Expanded metal	□
		With chips, obstacles, etc.	▲
<b>Environmental chemical conditions</b>		No aggressive chemicals	●
		With aggressive chemicals	□
<b>Temperature</b>		-40° / -20°	▲
		-20° / +80°	●
		+80° / +120°	□
		> 120°	▲
<b>Means of traction</b>		Manual (speed ≤ 4 Km/h)	●
		Mechanical (speed ≤ 16 Km/h)	▲
		Mechanical (speed > 16 Km/h)	▲



---

**elesa**

STANDARD MACHINE ELEMENTS WORLDWIDE

ELESA models all rights reserved in accordance with the law. Always mention the source when reproducing our drawings.