

# MMT. Handle

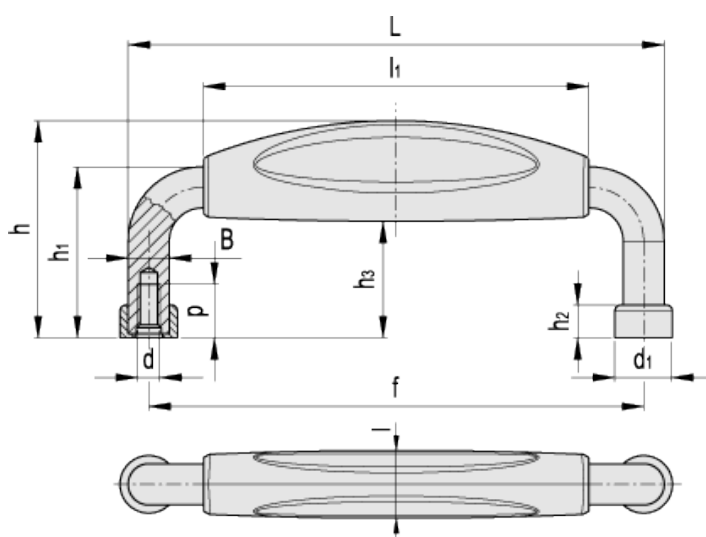

american unit  
metric unit

Elesa Standards		Main dimensions										Mounting holes		Weight
Code	Description	L	f	h	B	l	d <sub>1</sub>	h <sub>1</sub>	h <sub>2</sub>	h <sub>3</sub>	l <sub>1</sub>	d	p	lbs g
41051	MMT.130 M5	5.12 130	4.72±0.02 120±0.5	2.09 53	0.39 10	0.63 16	0.55 14	1.69 43	0.31 8	1.1 28	3.7 94	- M5	0.51 13	0.291 132
41061	MMT.190 M5	7.48 190	7.09±0.02 180±0.5	2.2 56	0.39 10	0.63 16	0.55 14	1.69 43	0.31 8	1.16 29.5	5.51 140	- M5	0.51 13	0.43 195

## Material

Steel round cross section bar with fine ground matte chrome-plated surface.  
Threaded blind holes.

## End bushes

Steel, chrome-plated matte surface.

## Heat insulation element

Glass-fibre reinforced polyamide based (PA) technopolymer, black colour, matte finish. Resistant to solvents, oils, greases and other chemical agents.

## Features and applications

The MMT. handle is particularly suitable for applications on surfaces subject to high temperatures. The internal aeration canals of the technopolymer heat insulation element minimize the heat transfer. Its particular shape offers a comfortable grip and puts the operator's fingers away from the heat source.

## Technical data

Figure n.1 shows the different temperatures reached in various points of the handle assembled to a plate stabilized at 200°C during laboratory tests.

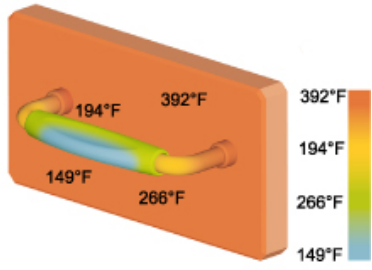

STANDARD MACHINE ELEMENTS WORLDWIDE

ELESA models all rights reserved in accordance with the law. Always mention the source when reproducing our drawings.