

REVISIONS			
REV.	DESCRIPTION	DATE	BY
E	UPDATED TO CURRENT REVISION	12/9/2019	KC

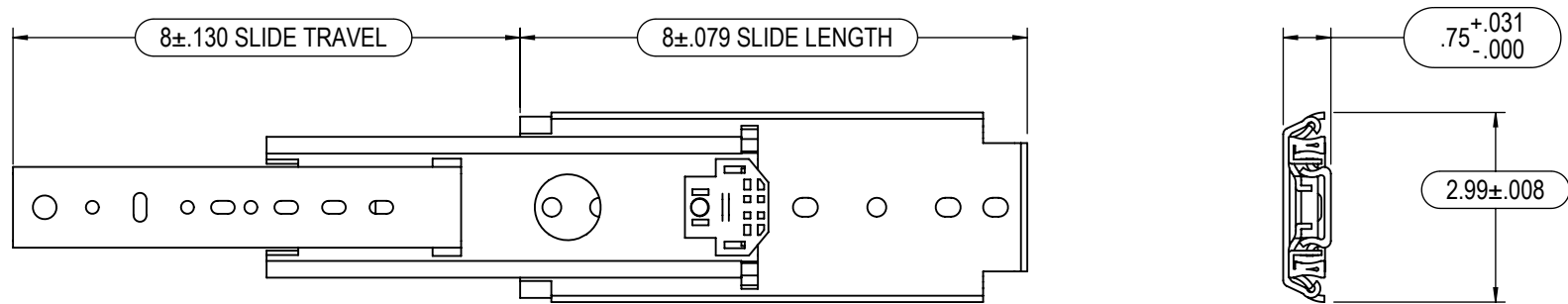

RECOMMENDED  
 INNER SLIDE MEMBER:  
 #10 MACHINE OR WOOD PAN HEAD SCREW FOR ALL THRU HOLES AND SLOTTED THRU HOLES.

OUTER SLIDE MEMBER:  
 1/4 HEX BOLT, #14 PAN HEAD WOOD SCREW FOR ALL THRU HOLES AND SLOTTED THRU HOLES.

SIDE SPACE = .750" - .783"

- NOTES:
1. DIMENSIONS APPLY AFTER FINISH.
  2. DO NOT SCALE DRAWING.
  3. BREAK ALL SHARP EDGES AND REMOVE ALL BURRS.
  4. MUST HAVE NO SCRATCHES, DINGS, DENTS OR SURFACE IMPERFECTIONS OTHER THAN SURFACE FINISH REQUIREMENTS.
  5. CRITICAL DIMENSIONS ARE INDICATED BY:
  6. TO BE INSPECTED TO 2.5 AQL SAMPLING PLAN UNLESS OTHERWISE STATED.
  7. ENSURE PACKAGING WILL PROVIDE ADEQUATE PROTECTION DURING TRANSPORT.
  8. GEOMETRIC FEATURES NOT DIMENSIONED ARE CONTROLLED BY 3D MODEL.

PART NUMBER: <b>I-DS-3300-8</b>		MATERIAL: <b>STEEL</b>	
DESCRIPTION: <b>8" 3300 SERIES SLIDE</b>		FINISH: <b>ZINC PLATED</b>	
		<h1>RYADON INC.</h1>	
UNLESS OTHERWISE SPECIFIED: DIMENSIONS ARE IN INCHES [mm]		PROPRIETARY AND CONFIDENTIAL THE INFORMATION CONTAINED IN THIS DRAWING IS THE SOLE PROPERTY OF RYADON INC. ANY REPRODUCTION IN PART OR AS A WHOLE WITHOUT THE WRITTEN PERMISSION OF RYADON INC. IS PROHIBITED.	
THIRD ANGLE PROJECTION 	SIZE <b>A</b>	ENGR KCHEN	SALES BW
		QUALITY PN	REV <b>E</b>
	SCALE: 1:3	DO NOT SCALE	SHEET 1 OF 2

6 5 4 3 2 1

D

D

C

C

B

B

A

A

6 5 4 3 2 1

6 5 4 3 2 1

D

C

B

A

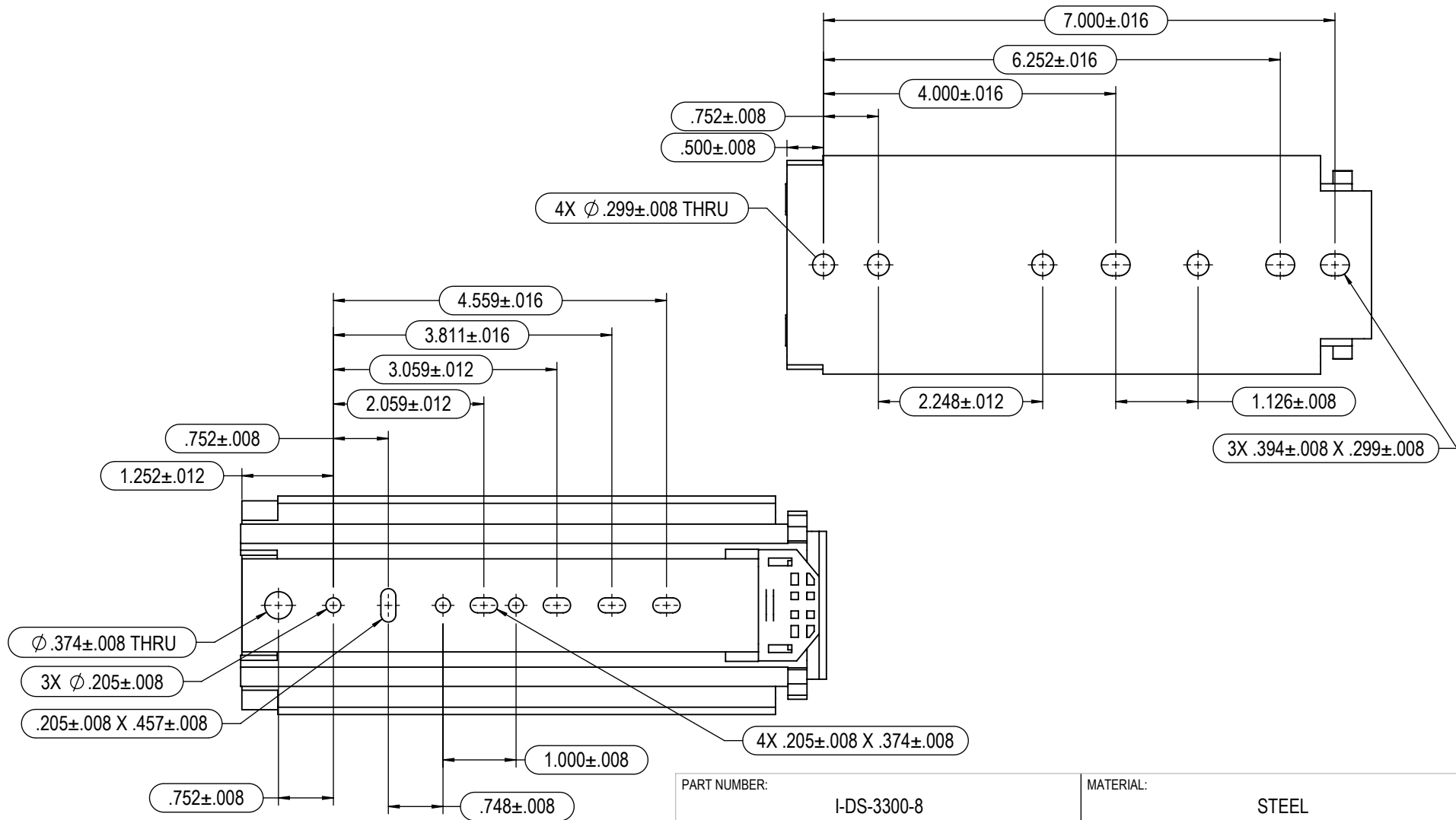

PART NUMBER:	I-DS-3300-8	MATERIAL:	STEEL
DESCRIPTION:	8" 3300 SERIES SLIDE	FINISH:	ZINC PLATED



# RYADON INC.

UNLESS OTHERWISE SPECIFIED: DIMENSIONS ARE IN INCHES [mm] .XX [X] = ± 0.03 [0.8mm] .XXX [XX] = ± 0.015 [0.38mm] .XXXX [XXX] = ± 0.0080 [0.203mm] FRACTIONAL = ± 1/32" ANGULAR = ± 1.0°	THIRD ANGLE PROJECTION					<table border="1"> <tr> <td>SIZE</td> <td>ENGR</td> <td>SALES</td> <td>QUALITY</td> <td>REV</td> </tr> <tr> <td><b>A</b></td> <td>KCHEN</td> <td></td> <td></td> <td><b>E</b></td> </tr> <tr> <td>DATE</td> <td>12/10/2019</td> <td></td> <td></td> <td></td> </tr> <tr> <td>SCALE: 1:2</td> <td>DO NOT SCALE</td> <td></td> <td></td> <td>SHEET 2 OF 2</td> </tr> </table>	SIZE	ENGR	SALES	QUALITY	REV	<b>A</b>	KCHEN			<b>E</b>	DATE	12/10/2019				SCALE: 1:2	DO NOT SCALE			SHEET 2 OF 2
	SIZE	ENGR	SALES	QUALITY	REV																					
	<b>A</b>	KCHEN			<b>E</b>																					
	DATE	12/10/2019																								
SCALE: 1:2	DO NOT SCALE			SHEET 2 OF 2																						
PROPRIETARY AND CONFIDENTIAL THE INFORMATION CONTAINED IN THIS DRAWING IS THE SOLE PROPERTY OF RYADON INC. ANY REPRODUCTION IN PART OR AS A WHOLE WITHOUT THE WRITTEN PERMISSION OF RYADON INC. IS PROHIBITED.																										
THIRD ANGLE PROJECTION																										
SIZE: <b>A</b>																										

- NOTES:
1. DIMENSIONS APPLY AFTER FINISH.
  2. DO NOT SCALE DRAWING.
  3. BREAK ALL SHARP EDGES AND REMOVE ALL BURRS.
  4. MUST HAVE NO SCRATCHES, DINGS, DENTS OR SURFACE IMPERFECTIONS OTHER THAN SURFACE FINISH REQUIREMENTS.
  5. CRITICAL DIMENSIONS ARE INDICATED BY:
  6. TO BE INSPECTED TO 2.5 AQL SAMPLING PLAN UNLESS OTHERWISE STATED.
  7. ENSURE PACKAGING WILL PROVIDE ADEQUATE PROTECTION DURING TRANSPORT.
  8. GEOMETRIC FEATURES NOT DIMENSIONED ARE CONTROLLED BY 3D MODEL.

6 5 4 3 2 1

6

5

4

3

2

1

## REVISIONS

REV.	DESCRIPTION	DATE	BY
E	UPDATED TO CURRENT REVISION	12/9/2019	KC

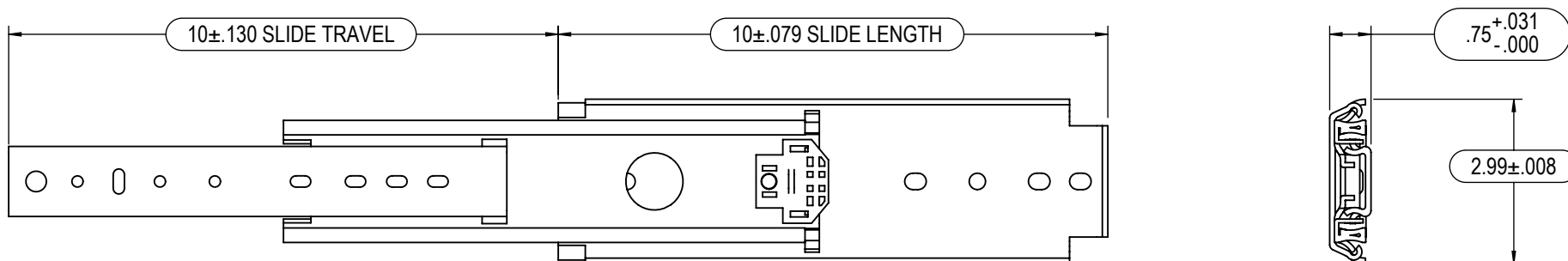

## RECOMMENDED

## INNER SLIDE MEMBER:

#10 MACHINE OR WOOD PAN HEAD SCREW FOR ALL THRU HOLES AND SLOTTED THRU HOLES.

## OUTER SLIDE MEMBER:

1/4 HEX BOLT, #14 PAN HEAD WOOD SCREW FOR ALL THRU HOLES AND SLOTTED THRU HOLES.

SIDE SPACE = .750" - .783"

## NOTES:

1. DIMENSIONS APPLY AFTER FINISH.
2. DO NOT SCALE DRAWING.
3. BREAK ALL SHARP EDGES AND REMOVE ALL BURRS.
4. MUST HAVE NO SCRATCHES, DINGS, DENTS OR SURFACE IMPERFECTIONS OTHER THAN SURFACE FINISH REQUIREMENTS.
5. CRITICAL DIMENSIONS ARE INDICATED BY:
6. TO BE INSPECTED TO 2.5 AQL SAMPLING PLAN UNLESS OTHERWISE STATED.
7. ENSURE PACKAGING WILL PROVIDE ADEQUATE PROTECTION DURING TRANSPORT.
8. GEOMETRIC FEATURES NOT DIMENSIONED ARE CONTROLLED BY 3D MODEL.

PART NUMBER:

I-DS-3300-10

MATERIAL:

STEEL

DESCRIPTION:

10" 3300 SERIES SLIDE

FINISH:

ZINC PLATED



# RYADON INC.

UNLESS OTHERWISE SPECIFIED:

DIMENSIONS ARE IN INCHES [mm]

.XX [X] = ± 0.03 [0.8mm]  
 .XXX [XX] = ± 0.015 [0.38mm]  
 .XXXX [XXX] = ± 0.0080 [0.203mm]  
 FRACTIONAL = ± 1/32"  
 ANGULAR: ± 1.0°

THIRD ANGLE PROJECTION



SIZE

## A

PROPRIETARY AND CONFIDENTIAL

THE INFORMATION CONTAINED IN THIS DRAWING IS THE SOLE PROPERTY OF RYADON INC. ANY REPRODUCTION IN PART OR AS A WHOLE WITHOUT THE WRITTEN PERMISSION OF RYADON INC. IS PROHIBITED.

NAME	ENGR	SALES	QUALITY	REV
KCHEN	BW	PN		E
DATE	12/10/2019	1/17/2020	12/20/2019	
SCALE: 1:3	DO NOT SCALE			SHEET 1 OF 2

6

5

4



3

2

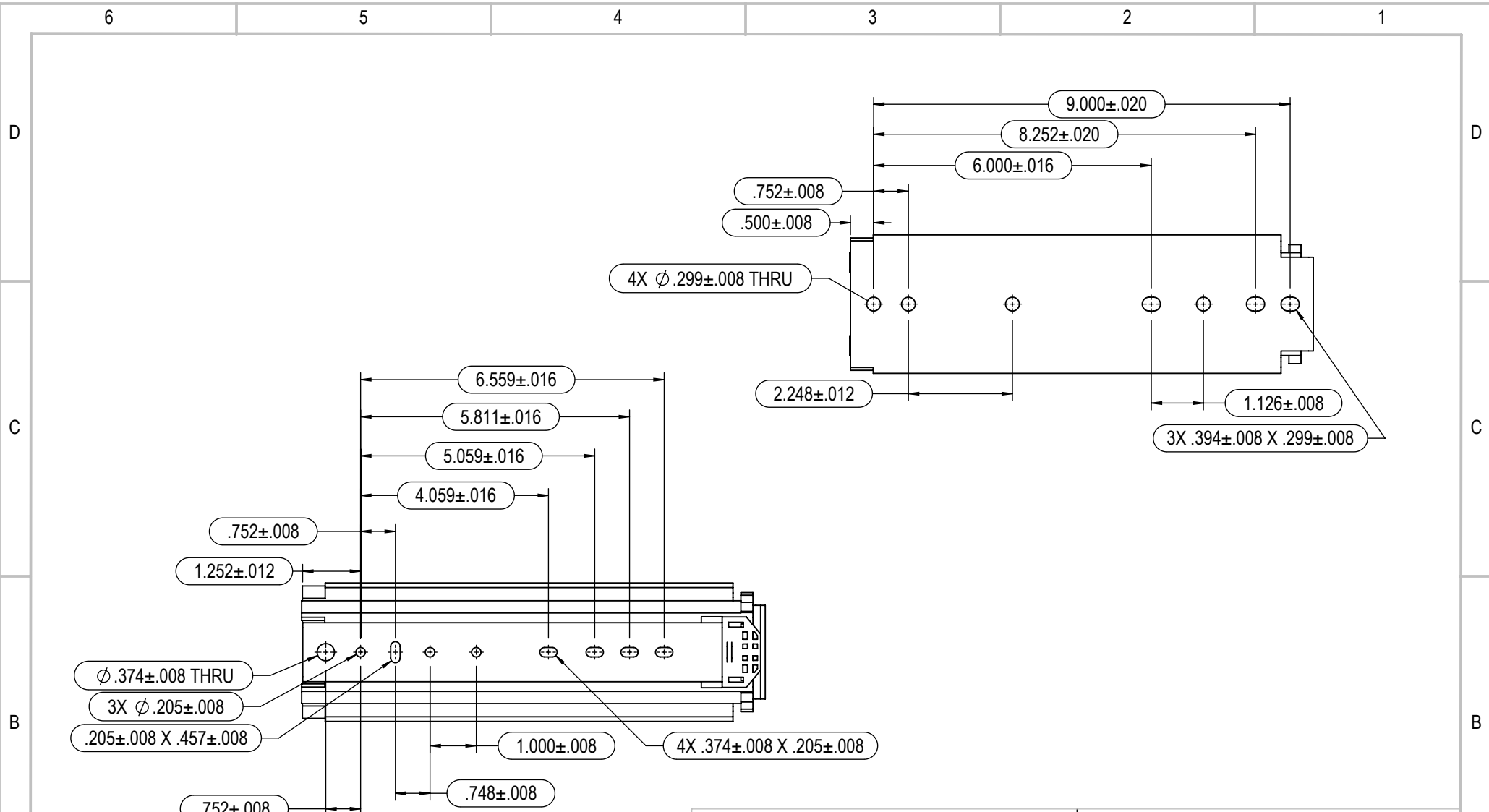
1



- NOTES:
1. DIMENSIONS APPLY AFTER FINISH.
  2. DO NOT SCALE DRAWING.
  3. BREAK ALL SHARP EDGES AND REMOVE ALL BURRS.
  4. MUST HAVE NO SCRATCHES, DINGS, DENTS OR SURFACE IMPERFECTIONS OTHER THAN SURFACE FINISH REQUIREMENTS.
  5. CRITICAL DIMENSIONS ARE INDICATED BY:
  6. TO BE INSPECTED TO 2.5 AQL SAMPLING PLAN UNLESS OTHERWISE STATED.
  7. ENSURE PACKAGING WILL PROVIDE ADEQUATE PROTECTION DURING TRANSPORT.
  8. GEOMETRIC FEATURES NOT DIMENSIONED ARE CONTROLLED BY 3D MODEL.

PART NUMBER: <b>I-DS-3300-10</b>		MATERIAL: <b>STEEL</b>	
DESCRIPTION: <b>10" 3300 SERIES SLIDE</b>		FINISH: <b>ZINC PLATED</b>	
		<h1>RYADON INC.</h1>	
UNLESS OTHERWISE SPECIFIED: DIMENSIONS ARE IN INCHES [mm]		PROPRIETARY AND CONFIDENTIAL THE INFORMATION CONTAINED IN THIS DRAWING IS THE SOLE PROPERTY OF RYADON INC. ANY REPRODUCTION IN PART OR AS A WHOLE WITHOUT THE WRITTEN PERMISSION OF RYADON INC. IS PROHIBITED.	
THIRD ANGLE PROJECTION 	SIZE <b>A</b>	ENGR KCHEN	SALES
	NAME	DATE 12/10/2019	QUALITY
	SCALE: 1:3	DO NOT SCALE	REV <b>E</b>
		SHEET 2 OF 2	

6

5

4

3

2

1

## REVISIONS

REV.	DESCRIPTION	DATE	BY
E	UPDATED TO CURRENT REVISION	12/9/2019	KC

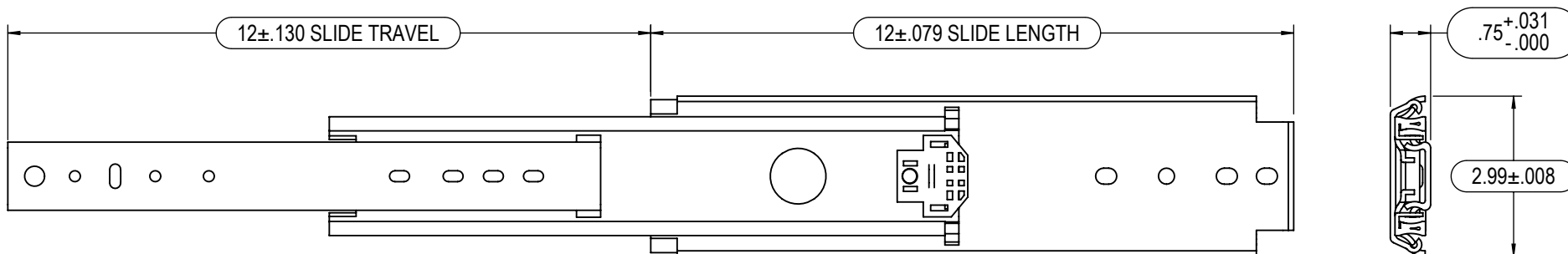

## RECOMMENDED

## INNER SLIDE MEMBER:

#10 MACHINE OR WOOD PAN HEAD SCREW FOR ALL THRU HOLES AND SLOTTED THRU HOLES.

## OUTER SLIDE MEMBER:

1/4 HEX BOLT, #14 PAN HEAD WOOD SCREW FOR ALL THRU HOLES AND SLOTTED THRU HOLES.

SIDE SPACE = .750" - .783"

## NOTES:

1. DIMENSIONS APPLY AFTER FINISH.
2. DO NOT SCALE DRAWING.
3. BREAK ALL SHARP EDGES AND REMOVE ALL BURRS.
4. MUST HAVE NO SCRATCHES, DINGS, DENTS OR SURFACE IMPERFECTIONS OTHER THAN SURFACE FINISH REQUIREMENTS.
5. CRITICAL DIMENSIONS ARE INDICATED BY: 
6. TO BE INSPECTED TO 2.5 AQL SAMPLING PLAN UNLESS OTHERWISE STATED.
7. ENSURE PACKAGING WILL PROVIDE ADEQUATE PROTECTION DURING TRANSPORT.
8. GEOMETRIC FEATURES NOT DIMENSIONED ARE CONTROLLED BY 3D MODEL.

PART NUMBER:

I-DS-3300-12

MATERIAL:

STEEL

DESCRIPTION:

12" 3300 SERIES SLIDE

FINISH:

ZINC PLATED



# RYADON INC.

UNLESS OTHERWISE SPECIFIED:

DIMENSIONS ARE IN INCHES [mm]

.XX [X] =  $\pm 0.03$  [0.8mm]  
 .XXX [XX] =  $\pm 0.015$  [0.38mm]  
 .XXXX [XXX] =  $\pm 0.0080$  [0.203mm]  
 FRACTIONAL =  $\pm 1/32$ "  
 ANGULAR:  $\pm 1.0^\circ$

THIRD ANGLE PROJECTION



SIZE

## A

PROPRIETARY AND CONFIDENTIAL

THE INFORMATION CONTAINED IN THIS DRAWING IS THE SOLE PROPERTY OF RYADON INC. ANY REPRODUCTION IN PART OR AS A WHOLE WITHOUT THE WRITTEN PERMISSION OF RYADON INC. IS PROHIBITED.

NAME	ENGR	SALES	QUALITY	REV
KCHEN	BW	PN		E
DATE	12/10/2019	1/17/2020	12/20/2019	
SCALE: 1:3	DO NOT SCALE			SHEET 1 OF 2

6

5

4

3

2

1

6 5 4 3 2 1

D

D

C

C

B

B

A

A

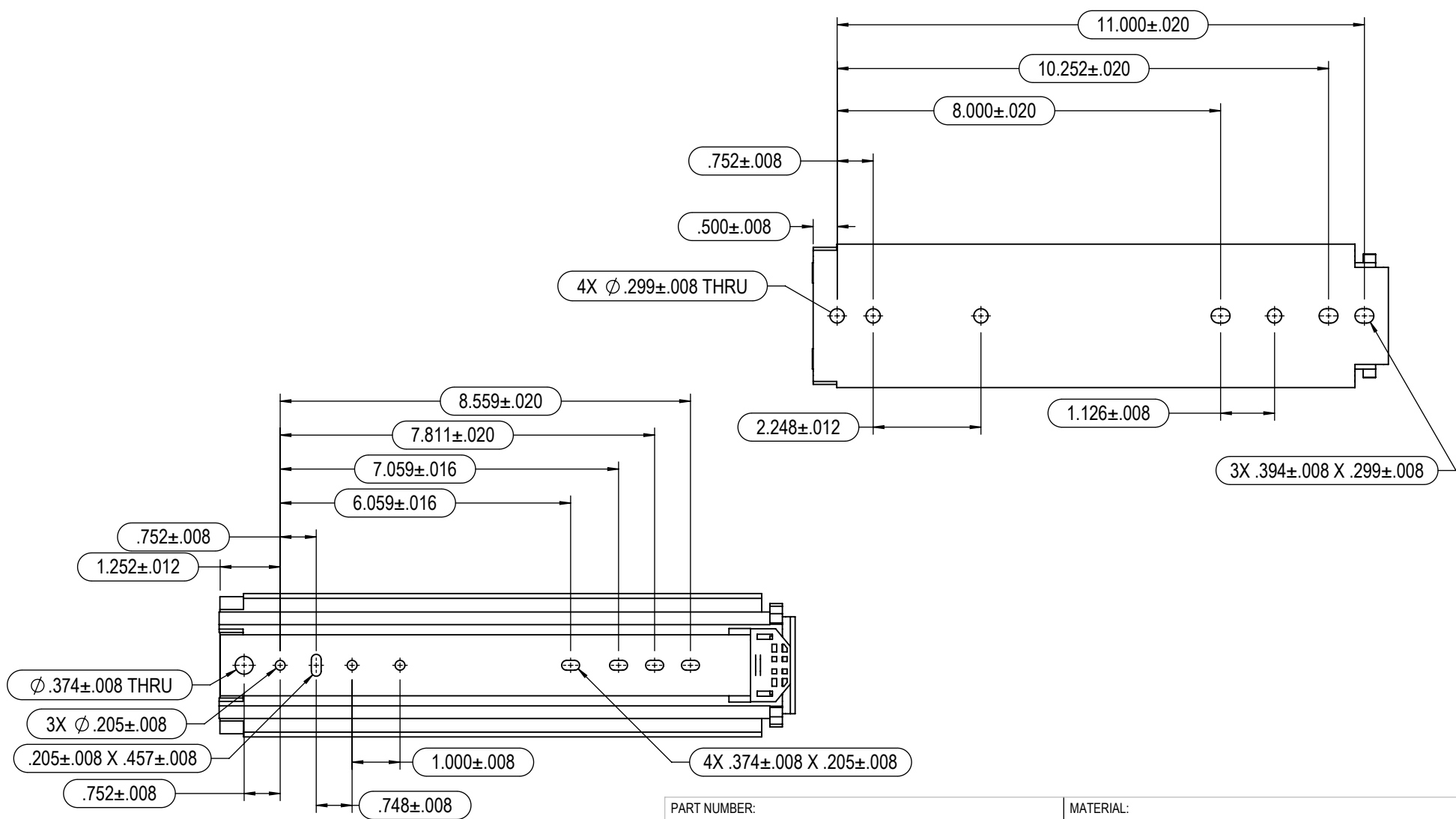

- NOTES:
1. DIMENSIONS APPLY AFTER FINISH.
  2. DO NOT SCALE DRAWING.
  3. BREAK ALL SHARP EDGES AND REMOVE ALL BURRS.
  4. MUST HAVE NO SCRATCHES, DINGS, DENTS OR SURFACE IMPERFECTIONS OTHER THAN SURFACE FINISH REQUIREMENTS.
  5. CRITICAL DIMENSIONS ARE INDICATED BY:
  6. TO BE INSPECTED TO 2.5 AQL SAMPLING PLAN UNLESS OTHERWISE STATED.
  7. ENSURE PACKAGING WILL PROVIDE ADEQUATE PROTECTION DURING TRANSPORT.
  8. GEOMETRIC FEATURES NOT DIMENSIONED ARE CONTROLLED BY 3D MODEL.

PART NUMBER:	I-DS-3300-12	MATERIAL:	STEEL
DESCRIPTION:	12" 3300 SERIES SLIDE	FINISH:	ZINC PLATED



# RYADON INC.

UNLESS OTHERWISE SPECIFIED: DIMENSIONS ARE IN INCHES [mm] .XX [X] = ± 0.03 [0.8mm] .XXX [XX] = ± 0.015 [0.38mm] .XXXX [XXX] = ± 0.0080 [0.203mm] FRACTIONAL = ± 1/32" ANGULAR: ± 1.0°	THIRD ANGLE PROJECTION					PROPRIETARY AND CONFIDENTIAL THE INFORMATION CONTAINED IN THIS DRAWING IS THE SOLE PROPERTY OF RYADON INC. ANY REPRODUCTION IN PART OR AS A WHOLE WITHOUT THE WRITTEN PERMISSION OF RYADON INC. IS PROHIBITED.						
		SIZE	ENGR	SALES	QUALITY	REV						
		A	NAME	KCHEN				E				
			DATE	12/10/2019								
		SCALE: 1:3	DO NOT SCALE		SHEET 2 OF 2							

6 5 4 3 2 1

6

5

4

3

2

1

## REVISIONS

REV.	DESCRIPTION	DATE	BY
E	UPDATED TO CURRENT REVISION	12/9/2019	KC

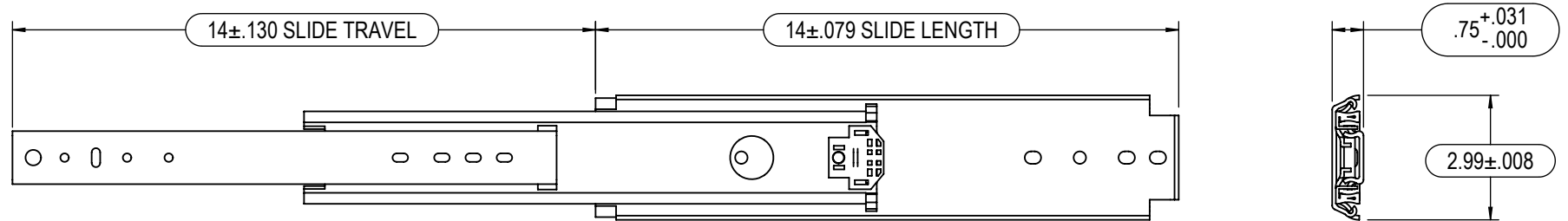

## RECOMMENDED

## INNER SLIDE MEMBER:

#10 MACHINE OR WOOD PAN HEAD SCREW FOR ALL THRU HOLES AND SLOTTED THRU HOLES.

## OUTER SLIDE MEMBER:

1/4 HEX BOLT, #14 PAN HEAD WOOD SCREW FOR ALL THRU HOLES AND SLOTTED THRU HOLES.

SIDE SPACE = .750" - .783"

## NOTES:

1. DIMENSIONS APPLY AFTER FINISH.
2. DO NOT SCALE DRAWING.
3. BREAK ALL SHARP EDGES AND REMOVE ALL BURRS.
4. MUST HAVE NO SCRATCHES, DINGS, DENTS OR SURFACE IMPERFECTIONS OTHER THAN SURFACE FINISH REQUIREMENTS.
5. CRITICAL DIMENSIONS ARE INDICATED BY: 
6. TO BE INSPECTED TO 2.5 AQL SAMPLING PLAN UNLESS OTHERWISE STATED.
7. ENSURE PACKAGING WILL PROVIDE ADEQUATE PROTECTION DURING TRANSPORT.
8. GEOMETRIC FEATURES NOT DIMENSIONED ARE CONTROLLED BY 3D MODEL.

PART NUMBER:

I-DS-3300-14

MATERIAL:

STEEL

DESCRIPTION:

14" 3300 SERIES SLIDE

FINISH:

ZINC PLATED



# RYADON INC.

UNLESS OTHERWISE SPECIFIED:

DIMENSIONS ARE IN INCHES [mm]

.XX [X] =  $\pm 0.03$  [0.8mm]  
 .XXX [XX] =  $\pm 0.015$  [0.38mm]  
 .XXXX [XXX] =  $\pm 0.0080$  [0.203mm]  
 FRACTIONAL =  $\pm 1/32$ "  
 ANGULAR:  $\pm 1.0^\circ$

PROPRIETARY AND CONFIDENTIAL  
 THE INFORMATION CONTAINED IN THIS DRAWING IS THE SOLE PROPERTY OF RYADON INC. ANY REPRODUCTION  
 IN PART OR AS A WHOLE WITHOUT THE WRITTEN PERMISSION OF RYADON INC. IS PROHIBITED.

THIRD ANGLE PROJECTION



SIZE

## A

ENGR

KCHEN

DATE

12/10/2019

SALES

BW

SCALE: 1:4

DO NOT SCALE

QUALITY

PN

12/20/2019

DO NOT SCALE

REV

E

SHEET 1 OF 2

SHEET 1 OF 2

6

5

4

3

2

1

D

D

C

C

B

B

A

A

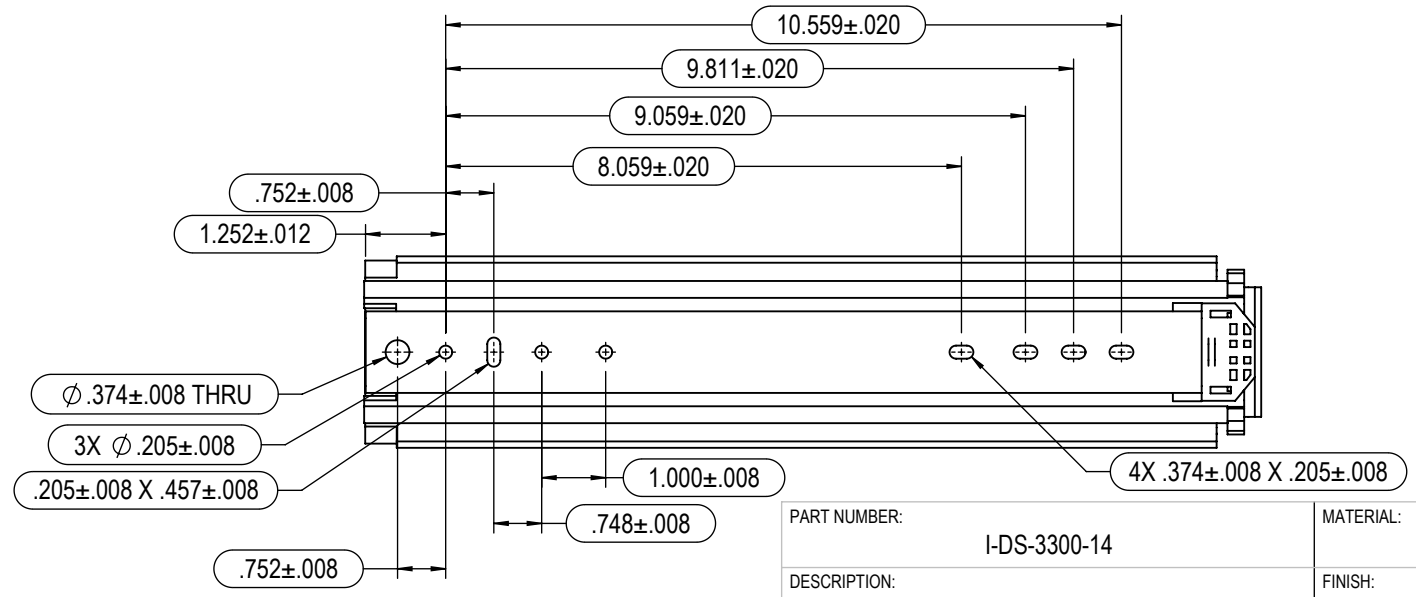
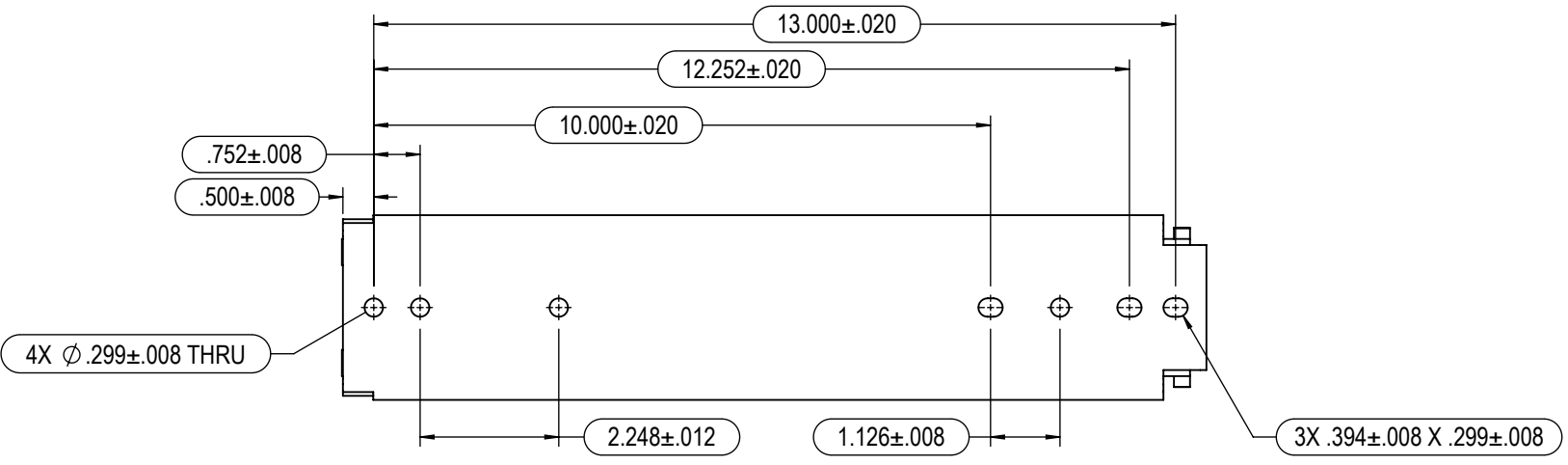

PART NUMBER:	I-DS-3300-14	MATERIAL:	STEEL
DESCRIPTION:	14" 3300 SERIES SLIDE	FINISH:	ZINC PLATED



# RYADON INC.

UNLESS OTHERWISE SPECIFIED: DIMENSIONS ARE IN INCHES [mm] .XX [X] = ± 0.03 [0.8mm] .XXX [XX] = ± 0.015 [0.38mm] .XXXX [XXX] = ± 0.0080 [0.203mm] FRACTIONAL = ± 1/32" ANGULAR = ± 1.0°	THIRD ANGLE PROJECTION					<table border="1"> <tr> <td>SIZE</td> <td>ENGR</td> <td>SALES</td> <td>QUALITY</td> <td>REV</td> </tr> <tr> <td><b>A</b></td> <td>KCHEN</td> <td></td> <td></td> <td><b>E</b></td> </tr> <tr> <td>SCALE: 1:3</td> <td colspan="2">DO NOT SCALE</td> <td colspan="2">SHEET 2 OF 2</td> </tr> </table>	SIZE	ENGR	SALES	QUALITY	REV	<b>A</b>	KCHEN			<b>E</b>	SCALE: 1:3	DO NOT SCALE		SHEET 2 OF 2	
	SIZE	ENGR	SALES	QUALITY	REV																
	<b>A</b>	KCHEN			<b>E</b>																
	SCALE: 1:3	DO NOT SCALE		SHEET 2 OF 2																	
PROPRIETARY AND CONFIDENTIAL THE INFORMATION CONTAINED IN THIS DRAWING IS THE SOLE PROPERTY OF RYADON INC. ANY REPRODUCTION IN PART OR AS A WHOLE WITHOUT THE WRITTEN PERMISSION OF RYADON INC. IS PROHIBITED.																					
NAME: KCHEN DATE: 12/10/2019																					
SCALE: 1:3      DO NOT SCALE      SHEET 2 OF 2																					

- NOTES:
1. DIMENSIONS APPLY AFTER FINISH.
  2. DO NOT SCALE DRAWING.
  3. BREAK ALL SHARP EDGES AND REMOVE ALL BURRS.
  4. MUST HAVE NO SCRATCHES, DINGS, DENTS OR SURFACE IMPERFECTIONS OTHER THAN SURFACE FINISH REQUIREMENTS.
  5. CRITICAL DIMENSIONS ARE INDICATED BY:
  6. TO BE INSPECTED TO 2.5 AQL SAMPLING PLAN UNLESS OTHERWISE STATED.
  7. ENSURE PACKAGING WILL PROVIDE ADEQUATE PROTECTION DURING TRANSPORT.
  8. GEOMETRIC FEATURES NOT DIMENSIONED ARE CONTROLLED BY 3D MODEL.



6

5

4

3

2

1

## REVISIONS

REV.	DESCRIPTION	DATE	BY
E	UPDATED TO CURRENT REVISION	12/9/2019	KC

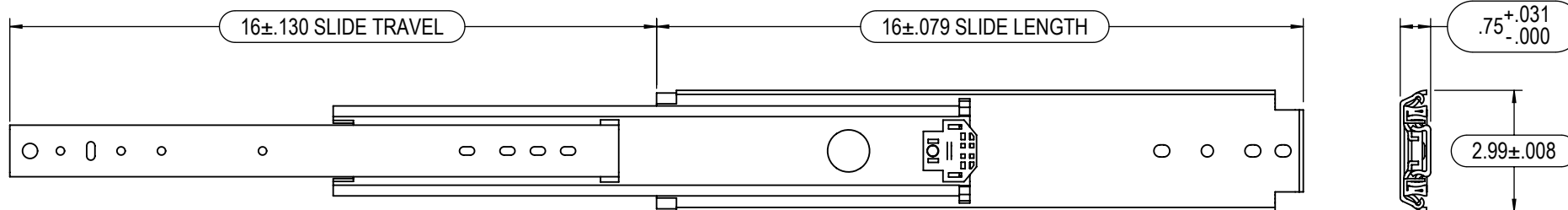

## RECOMMENDED

## INNER SLIDE MEMBER:

#10 MACHINE OR WOOD PAN HEAD SCREW FOR ALL THRU HOLES AND SLOTTED THRU HOLES.

## OUTER SLIDE MEMBER:

1/4 HEX BOLT, #14 PAN HEAD WOOD SCREW FOR ALL THRU HOLES AND SLOTTED THRU HOLES.

SIDE SPACE = .750" - .783"

## NOTES:

1. DIMENSIONS APPLY AFTER FINISH.
2. DO NOT SCALE DRAWING.
3. BREAK ALL SHARP EDGES AND REMOVE ALL BURRS.
4. MUST HAVE NO SCRATCHES, DINGS, DENTS OR SURFACE IMPERFECTIONS OTHER THAN SURFACE FINISH REQUIREMENTS.
5. CRITICAL DIMENSIONS ARE INDICATED BY: 
6. TO BE INSPECTED TO 2.5 AQL SAMPLING PLAN UNLESS OTHERWISE STATED.
7. ENSURE PACKAGING WILL PROVIDE ADEQUATE PROTECTION DURING TRANSPORT.
8. GEOMETRIC FEATURES NOT DIMENSIONED ARE CONTROLLED BY 3D MODEL.

PART NUMBER:

I-DS-3300-16

MATERIAL:

STEEL

DESCRIPTION:

16" 3300 SERIES SLIDE

FINISH:

ZINC PLATED



# RYADON INC.

UNLESS OTHERWISE SPECIFIED:

DIMENSIONS ARE IN INCHES [mm]

.XX [X] =  $\pm 0.03$  [0.8mm]  
 .XXX [XX] =  $\pm 0.015$  [0.38mm]  
 .XXXX [XXX] =  $\pm 0.0080$  [0.203mm]  
 FRACTIONAL =  $\pm 1/32$ "  
 ANGULAR =  $\pm 1.0^\circ$

THIRD ANGLE PROJECTION



SIZE

## A

PROPRIETARY AND CONFIDENTIAL  
 THE INFORMATION CONTAINED IN THIS DRAWING IS THE SOLE PROPERTY OF RYADON INC. ANY REPRODUCTION  
 IN PART OR AS A WHOLE WITHOUT THE WRITTEN PERMISSION OF RYADON INC. IS PROHIBITED.

NAME	ENGR	SALES	QUALITY	REV
KCHEN	BW	PN		E
DATE	12/10/2019	1/17/2020	12/20/2019	
SCALE: 1:4	DO NOT SCALE			SHEET 1 OF 2

6

5

4

3

2

1

D

D

C

C

B



B

A

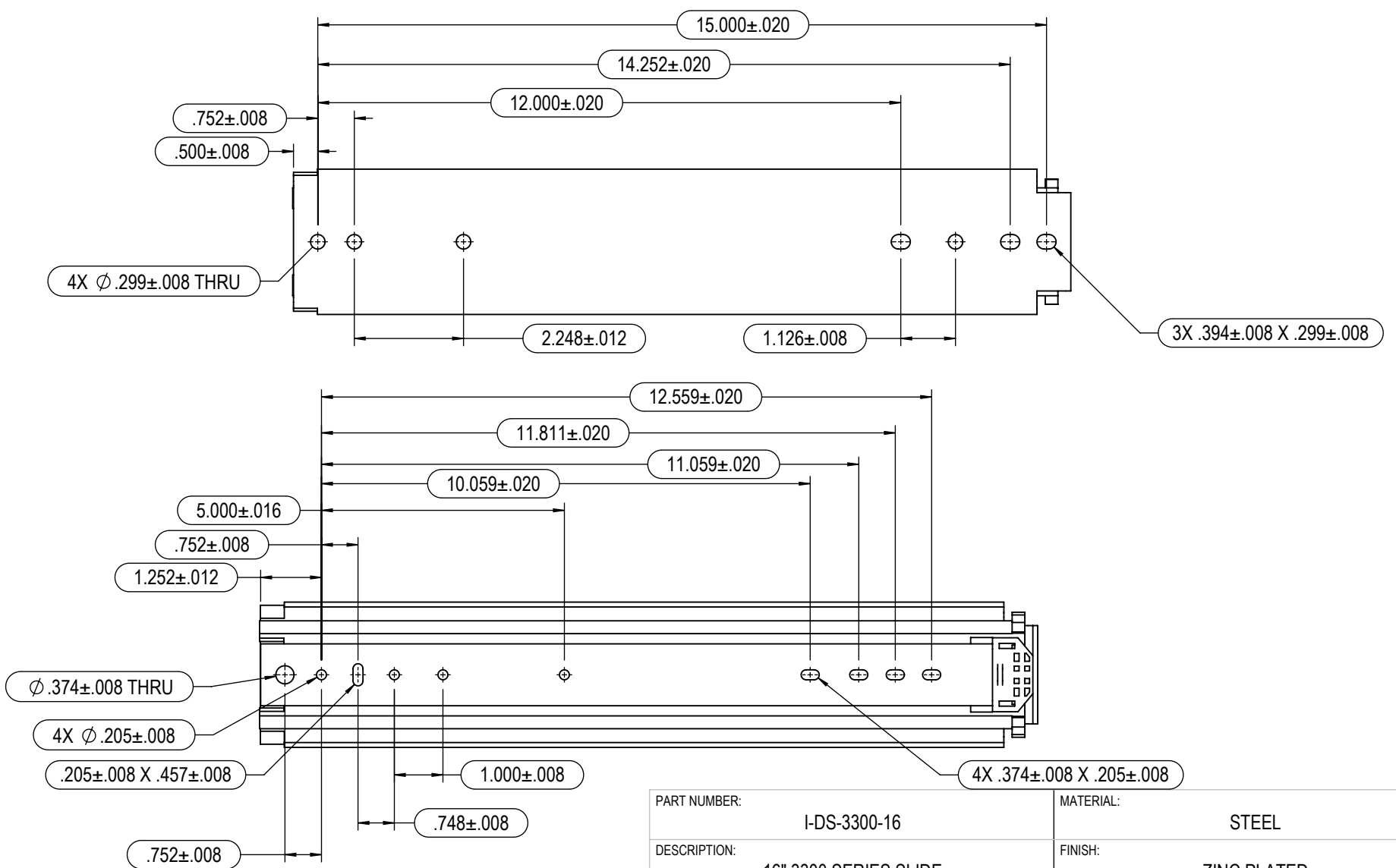
A



- NOTES:
1. DIMENSIONS APPLY AFTER FINISH.
  2. DO NOT SCALE DRAWING.
  3. BREAK ALL SHARP EDGES AND REMOVE ALL BURRS.
  4. MUST HAVE NO SCRATCHES, DINGS, DENTS OR SURFACE IMPERFECTIONS OTHER THAN SURFACE FINISH REQUIREMENTS.
  5. CRITICAL DIMENSIONS ARE INDICATED BY:
  6. TO BE INSPECTED TO 2.5 AQL SAMPLING PLAN UNLESS OTHERWISE STATED.
  7. ENSURE PACKAGING WILL PROVIDE ADEQUATE PROTECTION DURING TRANSPORT.
  8. GEOMETRIC FEATURES NOT DIMENSIONED ARE CONTROLLED BY 3D MODEL.

PART NUMBER: <b>I-DS-3300-16</b>		MATERIAL: <b>STEEL</b>																					
DESCRIPTION: <b>16" 3300 SERIES SLIDE</b>		FINISH: <b>ZINC PLATED</b>																					
		<h1>RYADON INC.</h1>																					
UNLESS OTHERWISE SPECIFIED: DIMENSIONS ARE IN INCHES [mm]		PROPRIETARY AND CONFIDENTIAL THE INFORMATION CONTAINED IN THIS DRAWING IS THE SOLE PROPERTY OF RYADON INC. ANY REPRODUCTION IN PART OR AS A WHOLE WITHOUT THE WRITTEN PERMISSION OF RYADON INC. IS PROHIBITED.																					
.XX [X] = ± 0.03 [0.8mm] .XXX [XX] = ± 0.015 [0.38mm] .XXXX [XXX] = ± 0.0080 [0.203mm] FRACTIONAL = ± 1/32" ANGULAR = ± 1.0°		THIRD ANGLE PROJECTION 	<table border="1"> <tr> <td>SIZE</td> <td>ENGR</td> <td>SALES</td> <td>QUALITY</td> <td>REV</td> </tr> <tr> <td><b>A</b></td> <td>KCHEN</td> <td></td> <td></td> <td><b>E</b></td> </tr> <tr> <td>DATE</td> <td>12/10/2019</td> <td></td> <td></td> <td></td> </tr> <tr> <td>SCALE: 1:3</td> <td></td> <td>DO NOT SCALE</td> <td></td> <td>SHEET 2 OF 2</td> </tr> </table>	SIZE	ENGR	SALES	QUALITY	REV	<b>A</b>	KCHEN			<b>E</b>	DATE	12/10/2019				SCALE: 1:3		DO NOT SCALE		SHEET 2 OF 2
SIZE	ENGR	SALES	QUALITY	REV																			
<b>A</b>	KCHEN			<b>E</b>																			
DATE	12/10/2019																						
SCALE: 1:3		DO NOT SCALE		SHEET 2 OF 2																			

6

5

4

3

2

1

## REVISIONS

REV.	DESCRIPTION	DATE	BY
E	UPDATED TO CURRENT REVISION	12/9/2019	KC

18±.130 SLIDE TRAVEL

18±.079 SLIDE LENGTH

.75<sup>+0.031</sup>  
-.000

2.99±.008

## RECOMMENDED

## INNER SLIDE MEMBER:

#10 MACHINE OR WOOD PAN HEAD SCREW FOR ALL THRU HOLES AND SLOTTED THRU HOLES.

## OUTER SLIDE MEMBER:

1/4 HEX BOLT, #14 PAN HEAD WOOD SCREW FOR ALL THRU HOLES AND SLOTTED THRU HOLES.

SIDE SPACE = .750" - .783"

## NOTES:

- DIMENSIONS APPLY AFTER FINISH.
- DO NOT SCALE DRAWING.
- BREAK ALL SHARP EDGES AND REMOVE ALL BURRS.
- MUST HAVE NO SCRATCHES, DINGS, DENTS OR SURFACE IMPERFECTIONS OTHER THAN SURFACE FINISH REQUIREMENTS.
- CRITICAL DIMENSIONS ARE INDICATED BY: 
- TO BE INSPECTED TO 2.5 AQL SAMPLING PLAN UNLESS OTHERWISE STATED.
- ENSURE PACKAGING WILL PROVIDE ADEQUATE PROTECTION DURING TRANSPORT.
- GEOMETRIC FEATURES NOT DIMENSIONED ARE CONTROLLED BY 3D MODEL.

PART NUMBER:

I-DS-3300-18

MATERIAL:

STEEL

DESCRIPTION:

18" 3300 SERIES SLIDE

FINISH:

ZINC PLATED



# RYADON INC.

UNLESS OTHERWISE SPECIFIED:

DIMENSIONS ARE IN INCHES [mm]

.XX [X] = ± 0.03 [0.8mm]  
 .XXX [XX] = ± 0.015 [0.38mm]  
 .XXXX [XXX] = ± 0.0080 [0.203mm]  
 FRACTIONAL = ± 1/32"  
 ANGULAR: ± 1.0°

THIRD ANGLE PROJECTION



SIZE

## A

PROPRIETARY AND CONFIDENTIAL  
 THE INFORMATION CONTAINED IN THIS DRAWING IS THE SOLE PROPERTY OF RYADON INC. ANY REPRODUCTION  
 IN PART OR AS A WHOLE WITHOUT THE WRITTEN PERMISSION OF RYADON INC. IS PROHIBITED.

NAME	ENGR	SALES	QUALITY	REV
KCHEN	BW	PN		E
DATE	12/10/2019	1/17/2020	12/20/2019	
SCALE: 1:4	DO NOT SCALE		SHEET 1 OF 2	

6

5

4

3

2

1



6 5 4 3 2 1

REVISIONS			
REV.	DESCRIPTION	DATE	BY
E	UPDATED TO CURRENT REVISION	12/9/2019	KC

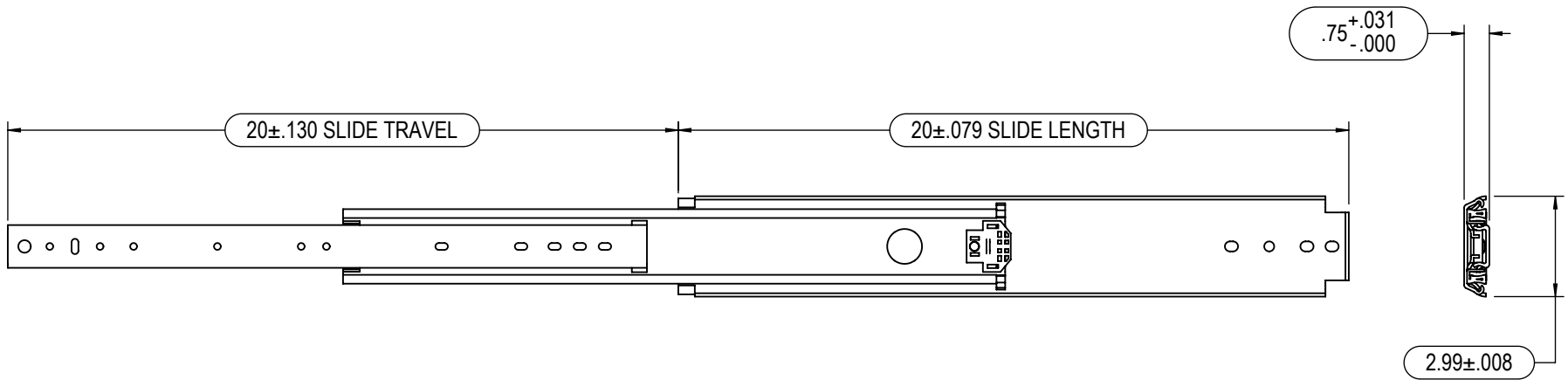



RECOMMENDED  
INNER SLIDE MEMBER:  
#10 MACHINE OR WOOD PAN HEAD SCREW FOR ALL THRU HOLES AND SLOTTED THRU HOLES.

OUTER SLIDE MEMBER:  
1/4 HEX BOLT, #14 PAN HEAD WOOD SCREW FOR ALL THRU HOLES AND SLOTTED THRU HOLES.

SIDE SPACE = .750" - .783"

- NOTES:
1. DIMENSIONS APPLY AFTER FINISH.
  2. DO NOT SCALE DRAWING.
  3. BREAK ALL SHARP EDGES AND REMOVE ALL BURRS.
  4. MUST HAVE NO SCRATCHES, DINGS, DENTS OR SURFACE IMPERFECTIONS OTHER THAN SURFACE FINISH REQUIREMENTS.
  5. CRITICAL DIMENSIONS ARE INDICATED BY:
  6. TO BE INSPECTED TO 2.5 AQL SAMPLING PLAN UNLESS OTHERWISE STATED.
  7. ENSURE PACKAGING WILL PROVIDE ADEQUATE PROTECTION DURING TRANSPORT.
  8. GEOMETRIC FEATURES NOT DIMENSIONED ARE CONTROLLED BY 3D MODEL.

PART NUMBER: <b>I-DS-3300-20</b>		MATERIAL: <b>STEEL</b>		
DESCRIPTION: <b>20" 3300 SERIES SLIDE</b>		FINISH: <b>ZINC PLATED</b>		
		<h1>RYADON INC.</h1>		
UNLESS OTHERWISE SPECIFIED: DIMENSIONS ARE IN INCHES [mm]		<p style="text-align: center; font-size: small;">PROPRIETARY AND CONFIDENTIAL THE INFORMATION CONTAINED IN THIS DRAWING IS THE SOLE PROPERTY OF RYADON INC. ANY REPRODUCTION IN PART OR AS A WHOLE WITHOUT THE WRITTEN PERMISSION OF RYADON INC. IS PROHIBITED.</p>		
<p style="font-size: x-small;">.XX [X] = ± 0.03 [0.8mm] .XXX [XX] = ± 0.015 [0.38mm] .XXXX [XXX] = ± 0.0080 [0.203mm] FRACTIONAL = ± 1/32" ANGULAR: ± 1.0°</p>	THIRD ANGLE PROJECTION		<div style="font-size: 2em; font-weight: bold; margin-bottom: 5px;">A</div> 	
	SIZE	ENGR		SALES
	NAME	KCHEN		BW
	DATE	12/10/2019	1/17/2020	
	SCALE: 1:5	DO NOT SCALE		
		QUALITY	REV	
		PN	<b>E</b>	
		12/20/2019	SHEET 1 OF 2	

6 5 4 3 2 1

D

D

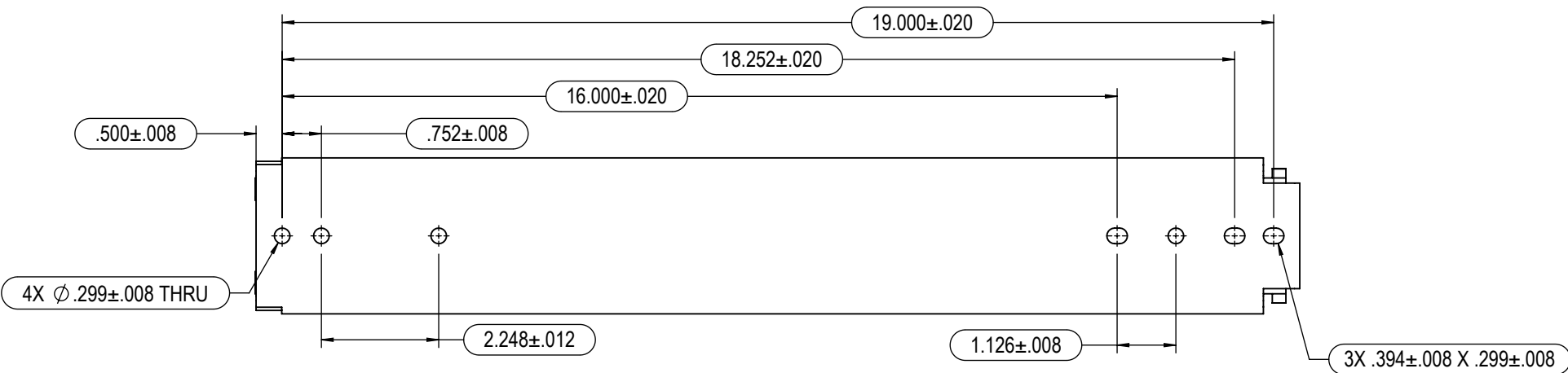

C

C

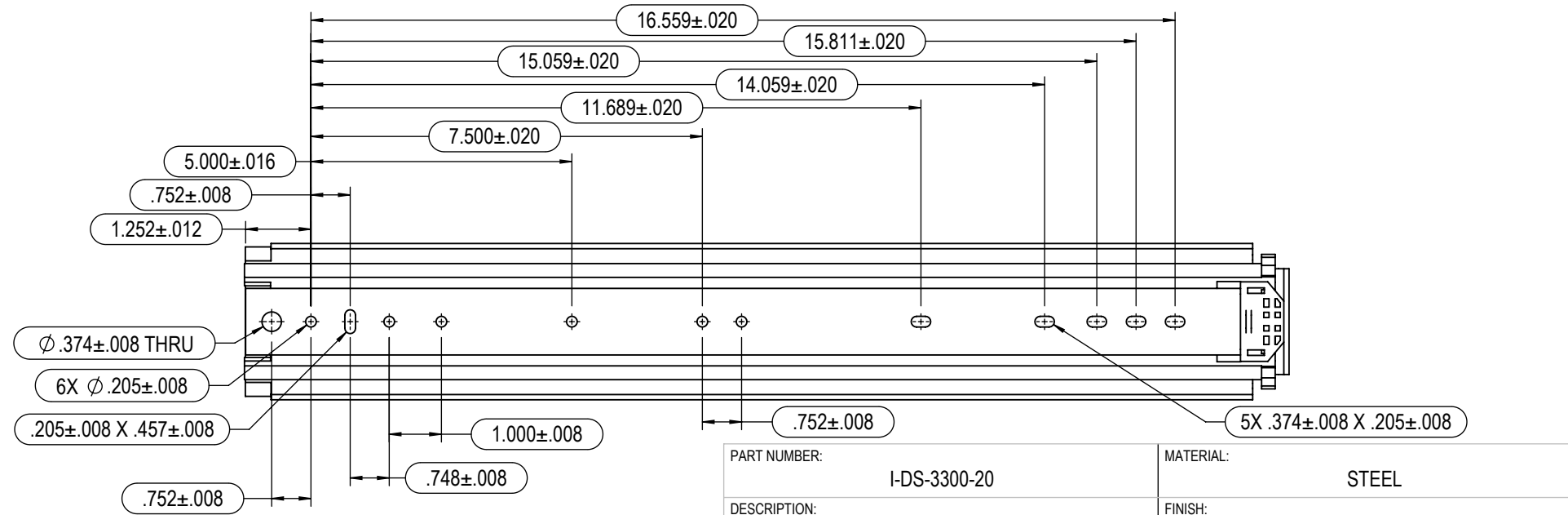

B

B

PART NUMBER:	I-DS-3300-20	MATERIAL:	STEEL
DESCRIPTION:	20" 3300 SERIES SLIDE	FINISH:	ZINC PLATED



# RYADON INC.

UNLESS OTHERWISE SPECIFIED: DIMENSIONS ARE IN INCHES [mm] .XX [X] = ± 0.03 [0.8mm] .XXX [XX] = ± 0.015 [0.38mm] .XXXX [XXX] = ± 0.0080 [0.203mm] FRACTIONAL = ± 1/32" ANGULAR = ± 1.0°	PROPRIETARY AND CONFIDENTIAL THE INFORMATION CONTAINED IN THIS DRAWING IS THE SOLE PROPERTY OF RYADON INC. ANY REPRODUCTION IN PART OR AS A WHOLE WITHOUT THE WRITTEN PERMISSION OF RYADON INC. IS PROHIBITED.				
	THIRD ANGLE PROJECTION	SIZE	ENGR	SALES	QUALITY
		<b>A</b>	KCHEN		
		DATE	12/10/2019		REV
		SCALE: 1:3	DO NOT SCALE		<b>E</b>
					SHEET 2 OF 2

- NOTES:
1. DIMENSIONS APPLY AFTER FINISH.
  2. DO NOT SCALE DRAWING.
  3. BREAK ALL SHARP EDGES AND REMOVE ALL BURRS.
  4. MUST HAVE NO SCRATCHES, DINGS, DENTS OR SURFACE IMPERFECTIONS OTHER THAN SURFACE FINISH REQUIREMENTS.
  5. CRITICAL DIMENSIONS ARE INDICATED BY:
  6. TO BE INSPECTED TO 2.5 AQL SAMPLING PLAN UNLESS OTHERWISE STATED.
  7. ENSURE PACKAGING WILL PROVIDE ADEQUATE PROTECTION DURING TRANSPORT.
  8. GEOMETRIC FEATURES NOT DIMENSIONED ARE CONTROLLED BY 3D MODEL.

A

A

REVISIONS			
REV.	DESCRIPTION	DATE	BY
E	UPDATED TO CURRENT REVISION	12/9/2019	KC

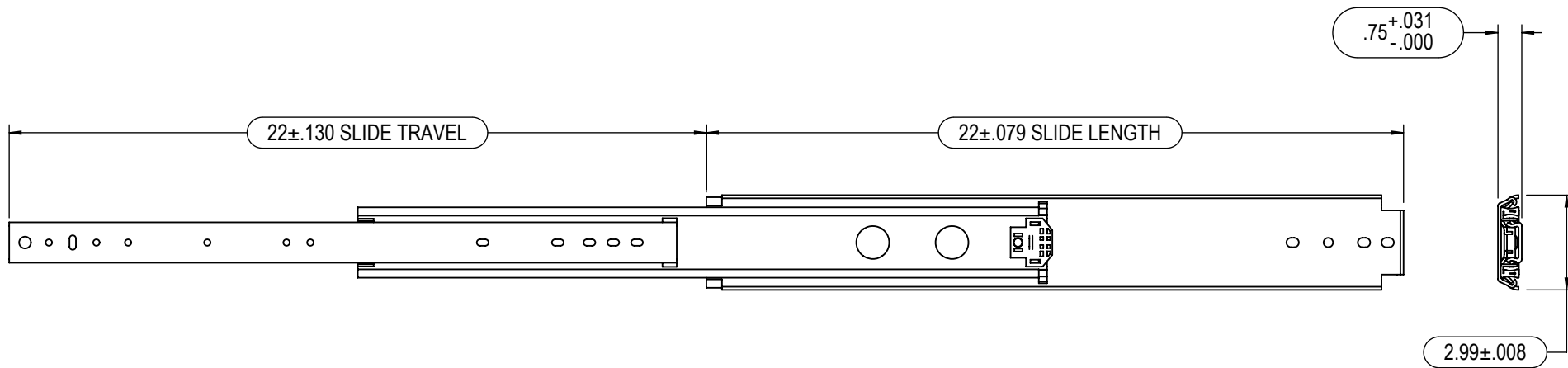



RECOMMENDED  
 INNER SLIDE MEMBER:  
 #10 MACHINE OR WOOD PAN HEAD SCREW FOR ALL THRU HOLES AND SLOTTED THRU HOLES.

OUTER SLIDE MEMBER:  
 1/4 HEX BOLT, #14 PAN HEAD WOOD SCREW FOR ALL THRU HOLES AND SLOTTED THRU HOLES.

SIDE SPACE = .750" - .783"

- NOTES:
1. DIMENSIONS APPLY AFTER FINISH.
  2. DO NOT SCALE DRAWING.
  3. BREAK ALL SHARP EDGES AND REMOVE ALL BURRS.
  4. MUST HAVE NO SCRATCHES, DINGS, DENTS OR SURFACE IMPERFECTIONS OTHER THAN SURFACE FINISH REQUIREMENTS.
  5. CRITICAL DIMENSIONS ARE INDICATED BY: 
  6. TO BE INSPECTED TO 2.5 AQL SAMPLING PLAN UNLESS OTHERWISE STATED.
  7. ENSURE PACKAGING WILL PROVIDE ADEQUATE PROTECTION DURING TRANSPORT.
  8. GEOMETRIC FEATURES NOT DIMENSIONED ARE CONTROLLED BY 3D MODEL.

PART NUMBER: I-DS-3300-22		MATERIAL: STEEL																					
DESCRIPTION: 22" 3300 SERIES SLIDE		FINISH: ZINC PLATED																					
		<h1>RYADON INC.</h1>																					
UNLESS OTHERWISE SPECIFIED: DIMENSIONS ARE IN INCHES [mm]		PROPRIETARY AND CONFIDENTIAL THE INFORMATION CONTAINED IN THIS DRAWING IS THE SOLE PROPERTY OF RYADON INC. ANY REPRODUCTION IN PART OR AS A WHOLE WITHOUT THE WRITTEN PERMISSION OF RYADON INC. IS PROHIBITED.																					
.XX [X] = ± 0.03 [0.8mm] .XXX [XX] = ± 0.015 [0.38mm] .XXXX [XXX] = ± 0.0080 [0.203mm] FRACTIONAL = ± 1/32" ANGULAR: ± 1.0°		THIRD ANGLE PROJECTION 	<table border="1"> <tr> <td>SIZE</td> <td>ENGR</td> <td>SALES</td> <td>QUALITY</td> <td>REV</td> </tr> <tr> <td><b>A</b></td> <td>KCHEN</td> <td>BW</td> <td>PN</td> <td><b>E</b></td> </tr> <tr> <td>DATE</td> <td>12/10/2019</td> <td>1/17/2020</td> <td>12/20/2019</td> <td></td> </tr> <tr> <td>SCALE: 1:5</td> <td colspan="2">DO NOT SCALE</td> <td colspan="2">SHEET 1 OF 2</td> </tr> </table>	SIZE	ENGR	SALES	QUALITY	REV	<b>A</b>	KCHEN	BW	PN	<b>E</b>	DATE	12/10/2019	1/17/2020	12/20/2019		SCALE: 1:5	DO NOT SCALE		SHEET 1 OF 2	
SIZE	ENGR	SALES	QUALITY	REV																			
<b>A</b>	KCHEN	BW	PN	<b>E</b>																			
DATE	12/10/2019	1/17/2020	12/20/2019																				
SCALE: 1:5	DO NOT SCALE		SHEET 1 OF 2																				

6 5 4 3 2 1

D

C

B

A

D

C

B

A

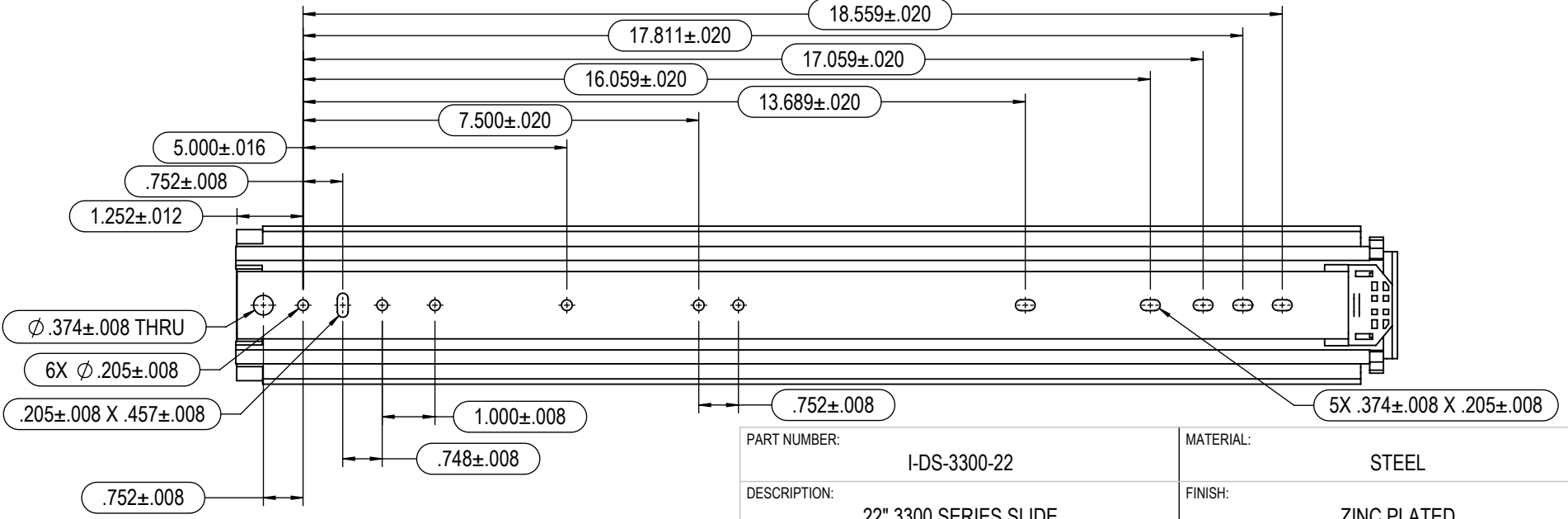
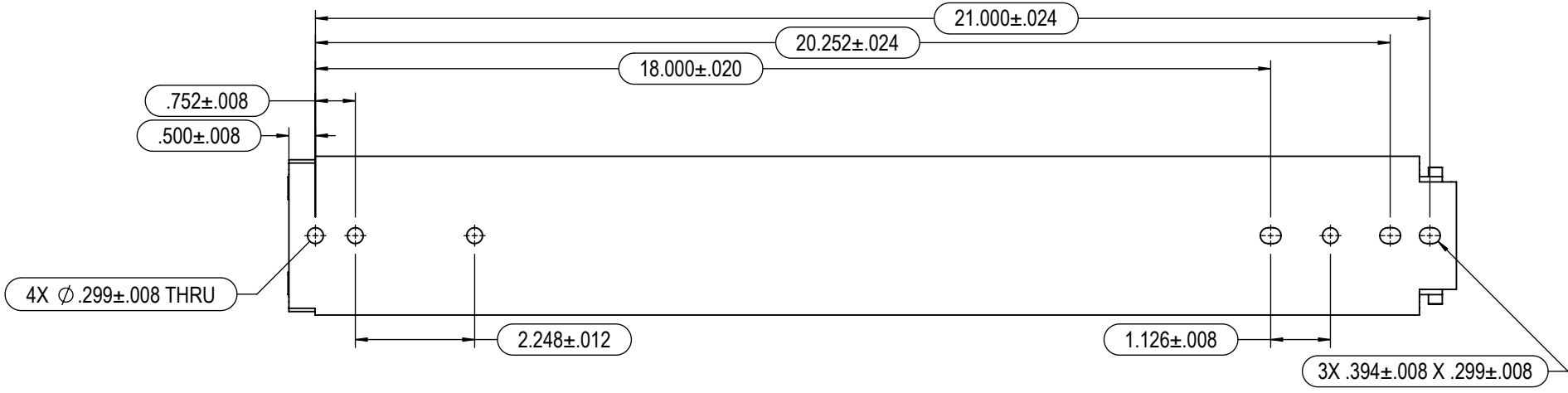

PART NUMBER:	I-DS-3300-22	MATERIAL:	STEEL
DESCRIPTION:	22" 3300 SERIES SLIDE	FINISH:	ZINC PLATED



# RYADON INC.

- NOTES:
1. DIMENSIONS APPLY AFTER FINISH.
  2. DO NOT SCALE DRAWING.
  3. BREAK ALL SHARP EDGES AND REMOVE ALL BURRS.
  4. MUST HAVE NO SCRATCHES, DINGS, DENTS OR SURFACE IMPERFECTIONS OTHER THAN SURFACE FINISH REQUIREMENTS.
  5. CRITICAL DIMENSIONS ARE INDICATED BY:
  6. TO BE INSPECTED TO 2.5 AQL SAMPLING PLAN UNLESS OTHERWISE STATED.
  7. ENSURE PACKAGING WILL PROVIDE ADEQUATE PROTECTION DURING TRANSPORT.
  8. GEOMETRIC FEATURES NOT DIMENSIONED ARE CONTROLLED BY 3D MODEL.

UNLESS OTHERWISE SPECIFIED: DIMENSIONS ARE IN INCHES [mm] .XX [X] = ± 0.03 [0.8mm] .XXX [XX] = ± 0.015 [0.38mm] .XXXX [XXX] = ± 0.0080 [0.203mm] FRACTIONAL = ± 1/32" ANGULAR: ± 1.0°	PROPRIETARY AND CONFIDENTIAL THE INFORMATION CONTAINED IN THIS DRAWING IS THE SOLE PROPERTY OF RYADON INC. ANY REPRODUCTION IN PART OR AS A WHOLE WITHOUT THE WRITTEN PERMISSION OF RYADON INC. IS PROHIBITED.				
	THIRD ANGLE PROJECTION	SIZE	ENGR	SALES	QUALITY
		<b>A</b>	KCHEN		
			DATE	SCALE: 1:3	DO NOT SCALE
				REV	<b>E</b>
					SHEET 2 OF 2

6 5 4 3 2 1



REVISIONS			
REV.	DESCRIPTION	DATE	BY
E	UPDATED TO CURRENT REVISION	12/9/2019	KC

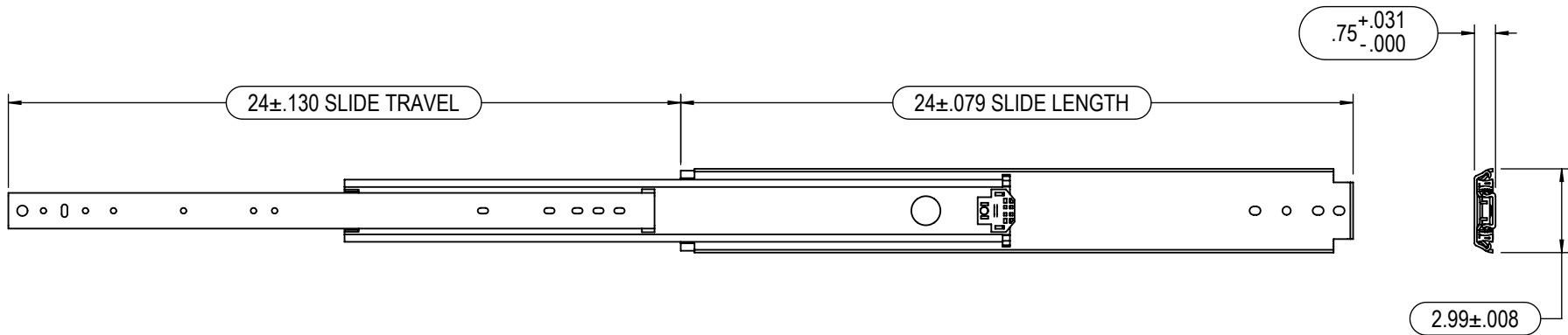



RECOMMENDED  
 INNER SLIDE MEMBER:  
 #10 MACHINE OR WOOD PAN HEAD SCREW FOR ALL THRU HOLES AND SLOTTED THRU HOLES.

OUTER SLIDE MEMBER:  
 1/4 HEX BOLT, #14 PAN HEAD WOOD SCREW FOR ALL THRU HOLES AND SLOTTED THRU HOLES.

SIDE SPACE = .750" - .783"

- NOTES:
1. DIMENSIONS APPLY AFTER FINISH.
  2. DO NOT SCALE DRAWING.
  3. BREAK ALL SHARP EDGES AND REMOVE ALL BURRS.
  4. MUST HAVE NO SCRATCHES, DINGS, DENTS OR SURFACE IMPERFECTIONS OTHER THAN SURFACE FINISH REQUIREMENTS.
  5. CRITICAL DIMENSIONS ARE INDICATED BY:
  6. TO BE INSPECTED TO 2.5 AQL SAMPLING PLAN UNLESS OTHERWISE STATED.
  7. ENSURE PACKAGING WILL PROVIDE ADEQUATE PROTECTION DURING TRANSPORT.
  8. GEOMETRIC FEATURES NOT DIMENSIONED ARE CONTROLLED BY 3D MODEL.

PART NUMBER: I-DS-3300-24		MATERIAL: STEEL			
DESCRIPTION: 24" 3300 SERIES SLIDE		FINISH: ZINC PLATED			
 <b>9001:2015</b>		<h1>RYADON INC.</h1>			
UNLESS OTHERWISE SPECIFIED: DIMENSIONS ARE IN INCHES [mm]		<small>PROPRIETARY AND CONFIDENTIAL</small> THE INFORMATION CONTAINED IN THIS DRAWING IS THE SOLE PROPERTY OF RYADON INC. ANY REPRODUCTION IN PART OR AS A WHOLE WITHOUT THE WRITTEN PERMISSION OF RYADON INC. IS PROHIBITED.			
<small>THIRD ANGLE PROJECTION</small> 	<b>SIZE</b>  <span style="font-size: 2em; font-weight: bold;">A</span>	ENGR	SALES	QUALITY	REV <b>E</b>
		KCHEN	BW	PN	
		DATE	12/10/2019	1/17/2020	
SCALE: 1:6		DO NOT SCALE		SHEET 1 OF 2	

6 5 4 3 2 1

D

D

C

C

B

B

A

A

6 5 4 3 2 1

D

D

C

C

B

B

A

A

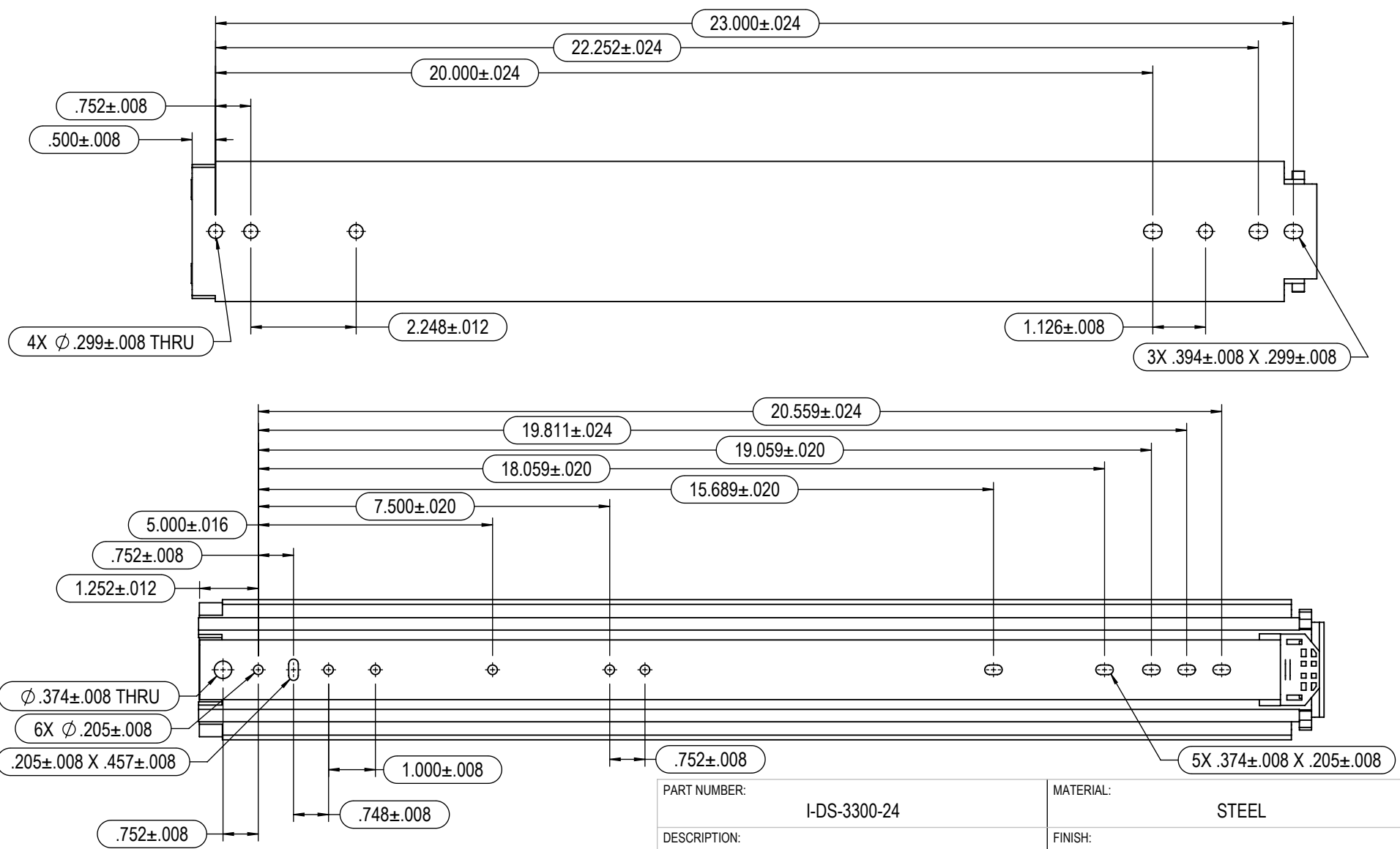

PART NUMBER:	I-DS-3300-24	MATERIAL:	STEEL
DESCRIPTION:	24" 3300 SERIES SLIDE	FINISH:	ZINC PLATED



# RYADON INC.

- NOTES:
1. DIMENSIONS APPLY AFTER FINISH.
  2. DO NOT SCALE DRAWING.
  3. BREAK ALL SHARP EDGES AND REMOVE ALL BURRS.
  4. MUST HAVE NO SCRATCHES, DINGS, DENTS OR SURFACE IMPERFECTIONS OTHER THAN SURFACE FINISH REQUIREMENTS.
  5. CRITICAL DIMENSIONS ARE INDICATED BY:
  6. TO BE INSPECTED TO 2.5 AQL SAMPLING PLAN UNLESS OTHERWISE STATED.
  7. ENSURE PACKAGING WILL PROVIDE ADEQUATE PROTECTION DURING TRANSPORT.
  8. GEOMETRIC FEATURES NOT DIMENSIONED ARE CONTROLLED BY 3D MODEL.

UNLESS OTHERWISE SPECIFIED: DIMENSIONS ARE IN INCHES [mm] .XX [X] = ± 0.03 [0.8mm] .XXX [XX] = ± 0.015 [0.38mm] .XXXX [XXX] = ± 0.0080 [0.203mm] FRACTIONAL = ± 1/32" ANGULAR: ± 1.0°	THIRD ANGLE PROJECTION				SIZE <b>A</b>	ENGR	SALES	QUALITY	REV <b>E</b>
	NAME		KCHEN			DATE	12/10/2019		
	SCALE: 1:3		DO NOT SCALE			SHEET 2 OF 2			

REVISIONS			
REV.	DESCRIPTION	DATE	BY
E	UPDATED TO CURRENT REVISION	12/9/2019	KC

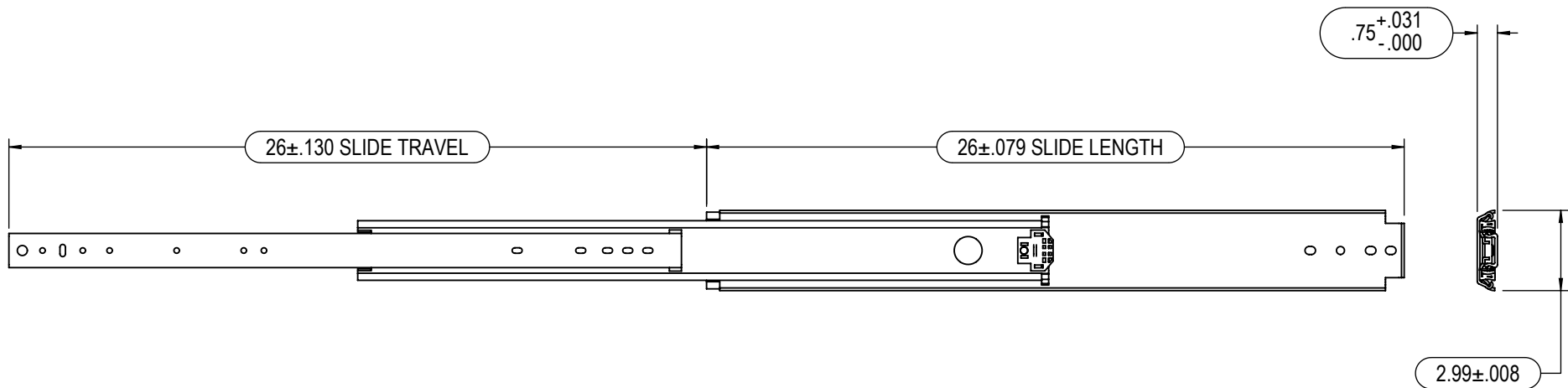

RECOMMENDED  
INNER SLIDE MEMBER:  
#10 MACHINE OR WOOD PAN HEAD SCREW FOR ALL THRU HOLES AND SLOTTED THRU HOLES.

OUTER SLIDE MEMBER:  
1/4 HEX BOLT, #14 PAN HEAD WOOD SCREW FOR ALL THRU HOLES AND SLOTTED THRU HOLES.

SIDE SPACE = .750" - .783"

- NOTES:
1. DIMENSIONS APPLY AFTER FINISH.
  2. DO NOT SCALE DRAWING.
  3. BREAK ALL SHARP EDGES AND REMOVE ALL BURRS.
  4. MUST HAVE NO SCRATCHES, DINGS, DENTS OR SURFACE IMPERFECTIONS OTHER THAN SURFACE FINISH REQUIREMENTS.
  5. CRITICAL DIMENSIONS ARE INDICATED BY:
  6. TO BE INSPECTED TO 2.5 AQL SAMPLING PLAN UNLESS OTHERWISE STATED.
  7. ENSURE PACKAGING WILL PROVIDE ADEQUATE PROTECTION DURING TRANSPORT.
  8. GEOMETRIC FEATURES NOT DIMENSIONED ARE CONTROLLED BY 3D MODEL.

PART NUMBER: I-DS-3300-26		MATERIAL: STEEL					
DESCRIPTION: 26" 3300 SERIES SLIDE		FINISH: ZINC PLATED					
UNLESS OTHERWISE SPECIFIED: DIMENSIONS ARE IN INCHES [mm]		PROPRIETARY AND CONFIDENTIAL THE INFORMATION CONTAINED IN THIS DRAWING IS THE SOLE PROPERTY OF RYADON INC. ANY REPRODUCTION IN PART OR AS A WHOLE WITHOUT THE WRITTEN PERMISSION OF RYADON INC. IS PROHIBITED.					
.XX [X] = ± 0.03 [0.8mm] .XXX [XX] = ± 0.015 [0.38mm] .XXXX [XXX] = ± 0.0080 [0.203mm] FRACTIONAL = ± 1/32" ANGULAR: ± 1.0°		THIRD ANGLE PROJECTION 	SIZE <b>A</b>	ENGR KCHEN	SALES BW	QUALITY PN	REV <b>E</b>
		SCALE: 1:6		DO NOT SCALE		SHEET 1 OF 2	

D

D

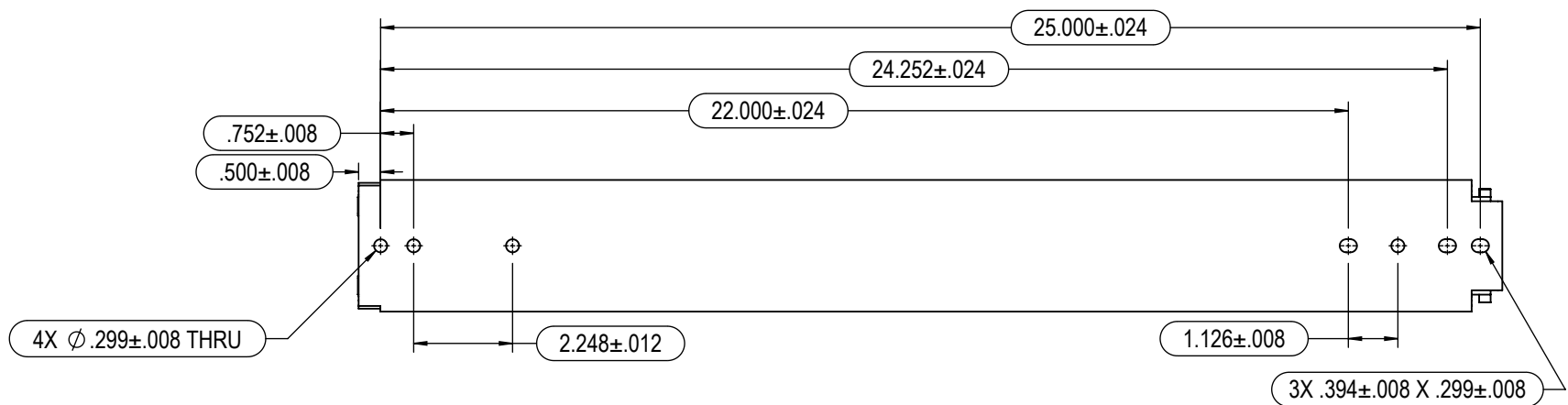

C

C

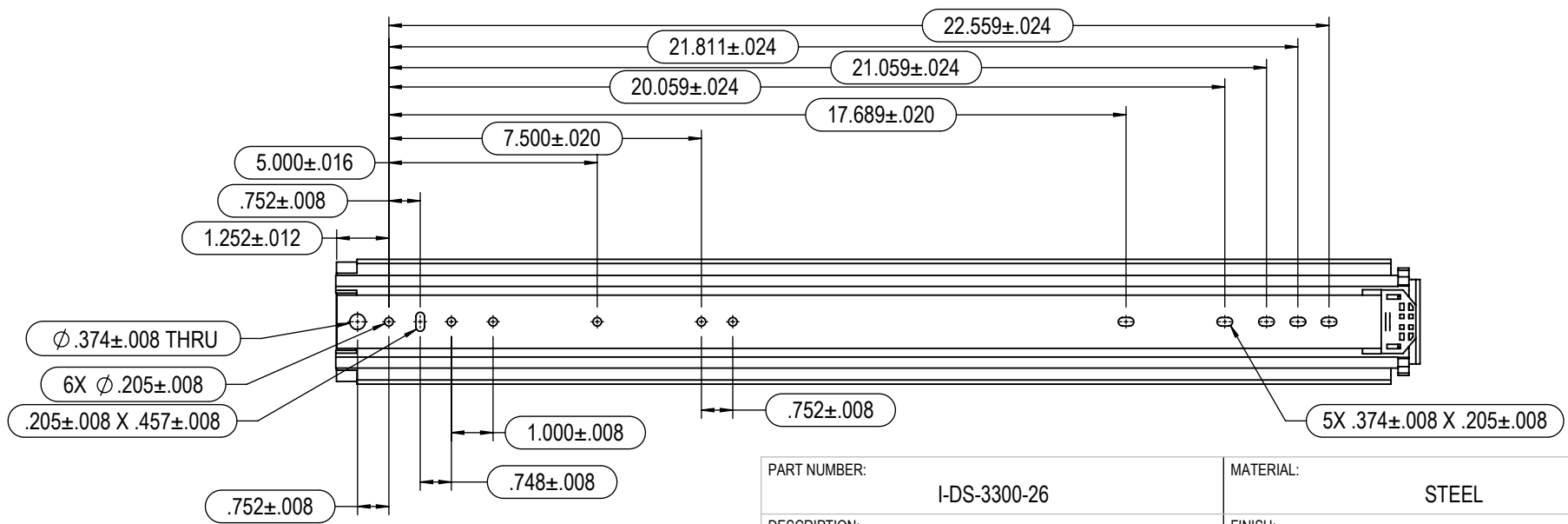

B

B

PART NUMBER:	I-DS-3300-26	MATERIAL:	STEEL
DESCRIPTION:	26" 3300 SERIES SLIDE	FINISH:	ZINC PLATED



# RYADON INC.

UNLESS OTHERWISE SPECIFIED: DIMENSIONS ARE IN INCHES [mm] .XX [X] = ± 0.03 [0.8mm] .XXX [XX] = ± 0.015 [0.38mm] .XXXX [XXX] = ± 0.0080 [0.203mm] FRACTIONAL = ± 1/32" ANGULAR = ± 1.0°	PROPRIETARY AND CONFIDENTIAL THE INFORMATION CONTAINED IN THIS DRAWING IS THE SOLE PROPERTY OF RYADON INC. ANY REPRODUCTION IN PART OR AS A WHOLE WITHOUT THE WRITTEN PERMISSION OF RYADON INC. IS PROHIBITED.					
	THIRD ANGLE PROJECTION	SIZE	ENGR	SALES	QUALITY	
		<b>A</b>	NAME	KCHEN		<b>E</b>
			DATE	12/10/2019		
		SCALE: 1:4	DO NOT SCALE	SHEET 2 OF 2		

A

A

- NOTES:
1. DIMENSIONS APPLY AFTER FINISH.
  2. DO NOT SCALE DRAWING.
  3. BREAK ALL SHARP EDGES AND REMOVE ALL BURRS.
  4. MUST HAVE NO SCRATCHES, DINGS, DENTS OR SURFACE IMPERFECTIONS OTHER THAN SURFACE FINISH REQUIREMENTS.
  5. CRITICAL DIMENSIONS ARE INDICATED BY:
  6. TO BE INSPECTED TO 2.5 AQL SAMPLING PLAN UNLESS OTHERWISE STATED.
  7. ENSURE PACKAGING WILL PROVIDE ADEQUATE PROTECTION DURING TRANSPORT.
  8. GEOMETRIC FEATURES NOT DIMENSIONED ARE CONTROLLED BY 3D MODEL.

6

5

4

3

2

1

## REVISIONS

REV.	DESCRIPTION	DATE	BY
E	UPDATED TO CURRENT REVISION	12/9/2019	KC

28±.130 SLIDE TRAVEL

28±.079 SLIDE LENGTH

.75<sup>+0.031</sup>  
-.000

2.99±.008

## RECOMMENDED

## INNER SLIDE MEMBER:

#10 MACHINE OR WOOD PAN HEAD SCREW FOR ALL THRU HOLES AND SLOTTED THRU HOLES.

## OUTER SLIDE MEMBER:

1/4 HEX BOLT, #14 PAN HEAD WOOD SCREW FOR ALL THRU HOLES AND SLOTTED THRU HOLES.

SIDE SPACE = .750" - .783"

## NOTES:

- DIMESIONS APPLY AFTER FINISH.
- DO NOT SCALE DRAWING.
- BREAK ALL SHARP EDGES AND REMOVE ALL BURRS.
- MUST HAVE NO SCRATCHES, DINGS, DENTS OR SURFACE IMPERFECTIONS OTHER THAN SURFACE FINISH REQUIREMENTS.
- CRITICAL DIMENSIONS ARE INDICATED BY: 
- TO BE INSPECTED TO 2.5 AQL SAMPLING PLAN UNLESS OTHERWISE STATED.
- ENSURE PACKAGING WILL PROVIDE ADEQUATE PROTECTION DURING TRANSPORT.
- GEOMETRIC FEATURES NOT DIMENSIONED ARE CONTROLLED BY 3D MODEL.

PART NUMBER:

I-DS-3300-28

MATERIAL:

STEEL

DESCRIPTION:

28" 3300 SERIES SLIDE

FINISH:

ZINC PLATED



# RYADON INC.

UNLESS OTHERWISE SPECIFIED:

DIMENSIONS ARE IN INCHES [mm]

.XX [X] = ± 0.03 [0.8mm]  
 .XXX [XX] = ± 0.015 [0.38mm]  
 .XXXX [XXX] = ± 0.0080 [0.203mm]  
 FRACTIONAL = ± 1/32"  
 ANGULAR: ± 1.0°

THIRD ANGLE PROJECTION



SIZE

## A

PROPRIETARY AND CONFIDENTIAL

THE INFORMATION CONTAINED IN THIS DRAWING IS THE SOLE PROPERTY OF RYADON INC. ANY REPRODUCTION IN PART OR AS A WHOLE WITHOUT THE WRITTEN PERMISSION OF RYADON INC. IS PROHIBITED.

NAME	ENGR	SALES	QUALITY	REV
KCHEN	BW	PN		E
DATE	12/10/2019	1/17/2020	12/20/2019	
SCALE: 1:7	DO NOT SCALE			SHEET 1 OF 2

6

5

4

3

2

1



6

5

4

3

2

1

## REVISIONS

REV.	DESCRIPTION	DATE	BY
E	UPDATED TO CURRENT REVISION	12/9/2019	KC

30±.130 SLIDE TRAVEL

30±.079 SLIDE LENGTH

.75<sup>+.031</sup>  
-.000

2.99±.008

## RECOMMENDED

## INNER SLIDE MEMBER:

#10 MACHINE OR WOOD PAN HEAD SCREW FOR ALL THRU HOLES AND SLOTTED THRU HOLES.

## OUTER SLIDE MEMBER:

1/4 HEX BOLT, #14 PAN HEAD WOOD SCREW FOR ALL THRU HOLES AND SLOTTED THRU HOLES.

SIDE SPACE = .750" - .783"

## NOTES:

1. DIMENSIONS APPLY AFTER FINISH.
2. DO NOT SCALE DRAWING.
3. BREAK ALL SHARP EDGES AND REMOVE ALL BURRS.
4. MUST HAVE NO SCRATCHES, DINGS, DENTS OR SURFACE IMPERFECTIONS OTHER THAN SURFACE FINISH REQUIREMENTS.
5. CRITICAL DIMENSIONS ARE INDICATED BY: 
6. TO BE INSPECTED TO 2.5 AQL SAMPLING PLAN UNLESS OTHERWISE STATED.
7. ENSURE PACKAGING WILL PROVIDE ADEQUATE PROTECTION DURING TRANSPORT.
8. GEOMETRIC FEATURES NOT DIMENSIONED ARE CONTROLLED BY 3D MODEL.

PART NUMBER:

I-DS-3300-30

MATERIAL:

STEEL

DESCRIPTION:

30" 3300 SERIES SLIDE

FINISH:

ZINC PLATED



# RYADON INC.

UNLESS OTHERWISE SPECIFIED:

DIMENSIONS ARE IN INCHES [mm]

.XX [X] = ± 0.03 [0.8mm]  
 .XXX [XX] = ± 0.015 [0.38mm]  
 .XXXX [XXX] = ± 0.0080 [0.203mm]  
 FRACTIONAL = ± 1/32"  
 ANGULAR: ± 1.0°

THIRD ANGLE PROJECTION



SIZE

## A

PROPRIETARY AND CONFIDENTIAL  
 THE INFORMATION CONTAINED IN THIS DRAWING IS THE SOLE PROPERTY OF RYADON INC. ANY REPRODUCTION  
 IN PART OR AS A WHOLE WITHOUT THE WRITTEN PERMISSION OF RYADON INC. IS PROHIBITED.

NAME	ENGR	SALES	QUALITY	REV
KCHEN	BW	PN		E
DATE	12/10/2019	1/17/2020	12/20/2019	
SCALE: 1:7	DO NOT SCALE			SHEET 1 OF 2

6

5

4

3

2

1

6 5 4 3 2 1

D

D

C

C

B

B

A

A

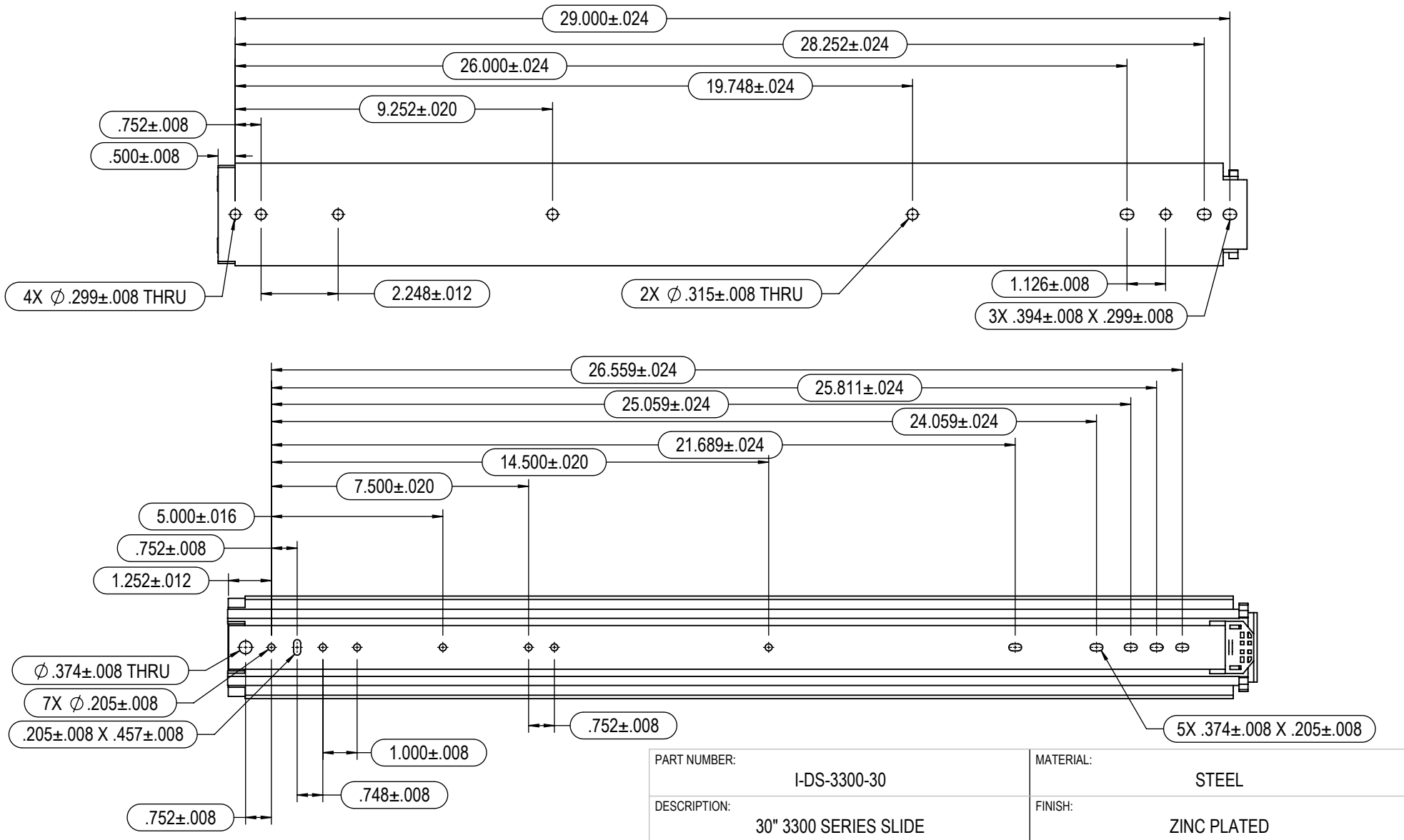

PART NUMBER:	I-DS-3300-30	MATERIAL:	STEEL
DESCRIPTION:	30" 3300 SERIES SLIDE	FINISH:	ZINC PLATED



9001:2015

# RYADON INC.

UNLESS OTHERWISE SPECIFIED: DIMENSIONS ARE IN INCHES [mm] .XX [X] = ± 0.03 [0.8mm] .XXX [XX] = ± 0.015 [0.38mm] .XXXX [XXX] = ± 0.0080 [0.203mm] FRACTIONAL = ± 1/32" ANGULAR = ± 1.0°	PROPRIETARY AND CONFIDENTIAL THE INFORMATION CONTAINED IN THIS DRAWING IS THE SOLE PROPERTY OF RYADON INC. ANY REPRODUCTION IN PART OR AS A WHOLE WITHOUT THE WRITTEN PERMISSION OF RYADON INC. IS PROHIBITED.					
	THIRD ANGLE PROJECTION 	SIZE <b>A</b>	ENGR KCHEN	SALES	QUALITY	REV <b>E</b>
		NAME DATE	12/10/2019	SCALE: 1:4 DO NOT SCALE	SHEET 2 OF 2	

- NOTES:
- DIMENSIONS APPLY AFTER FINISH.
  - DO NOT SCALE DRAWING.
  - BREAK ALL SHARP EDGES AND REMOVE ALL BURRS.
  - MUST HAVE NO SCRATCHES, DINGS, DENTS OR SURFACE IMPERFECTIONS OTHER THAN SURFACE FINISH REQUIREMENTS.
  - CRITICAL DIMENSIONS ARE INDICATED BY:
  - TO BE INSPECTED TO 2.5 AQL SAMPLING PLAN UNLESS OTHERWISE STATED.
  - ENSURE PACKAGING WILL PROVIDE ADEQUATE PROTECTION DURING TRANSPORT.
  - GEOMETRIC FEATURES NOT DIMENSIONED ARE CONTROLLED BY 3D MODEL.

6 5 4 3 2 1



REVISIONS			
REV.	DESCRIPTION	DATE	BY
E	UPDATED TO CURRENT REVISION	12/9/2019	KC

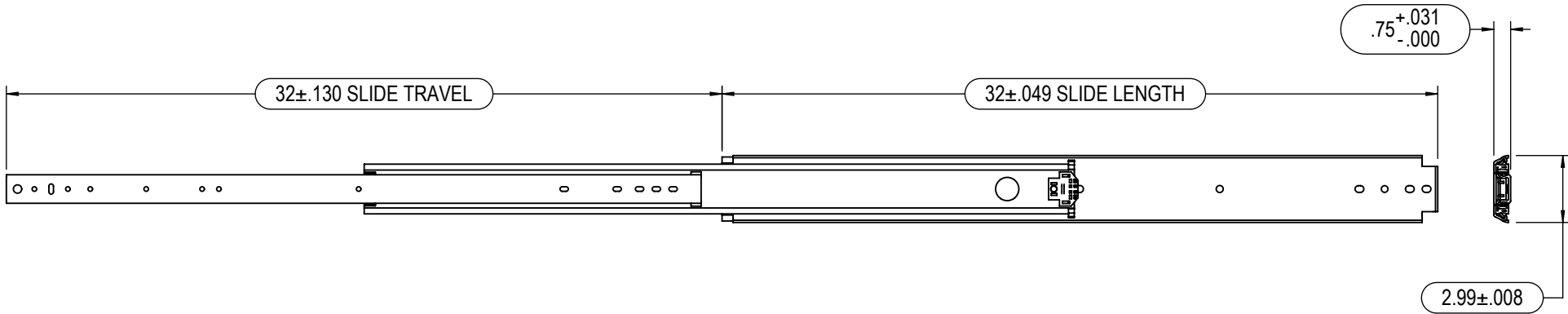

RECOMMENDED  
 INNER SLIDE MEMBER:  
 #10 MACHINE OR WOOD PAN HEAD SCREW FOR ALL THRU HOLES AND SLOTTED THRU HOLES.

OUTER SLIDE MEMBER:  
 1/4 HEX BOLT, #14 PAN HEAD WOOD SCREW FOR ALL THRU HOLES AND SLOTTED THRU HOLES.

SIDE SPACE = .750" - .783"

- NOTES:
1. DIMENSIONS APPLY AFTER FINISH.
  2. DO NOT SCALE DRAWING.
  3. BREAK ALL SHARP EDGES AND REMOVE ALL BURRS.
  4. MUST HAVE NO SCRATCHES, DINGS, DENTS OR SURFACE IMPERFECTIONS OTHER THAN SURFACE FINISH REQUIREMENTS.
  5. CRITICAL DIMENSIONS ARE INDICATED BY:
  6. TO BE INSPECTED TO 2.5 AQL SAMPLING PLAN UNLESS OTHERWISE STATED.
  7. ENSURE PACKAGING WILL PROVIDE ADEQUATE PROTECTION DURING TRANSPORT.
  8. GEOMETRIC FEATURES NOT DIMENSIONED ARE CONTROLLED BY 3D MODEL.

PART NUMBER: I-DS-3300-32		MATERIAL: STEEL					
DESCRIPTION: 32" 3300 SERIES SLIDE		FINISH: ZINC PLATED					
UNLESS OTHERWISE SPECIFIED: DIMENSIONS ARE IN INCHES [mm]		PROPRIETARY AND CONFIDENTIAL THE INFORMATION CONTAINED IN THIS DRAWING IS THE SOLE PROPERTY OF RYADON INC. ANY REPRODUCTION IN PART OR AS A WHOLE WITHOUT THE WRITTEN PERMISSION OF RYADON INC. IS PROHIBITED.					
.XX [X] = ± 0.03 [0.8mm] .XXX [XX] = ± 0.015 [0.38mm] .XXXX [XXX] = ± 0.0080 [0.203mm] FRACTIONAL = ± 1/32" ANGULAR = ± 1.0°		THIRD ANGLE PROJECTION 	SIZE <b>A</b>	ENGR KCHEN	SALES BW	QUALITY PN	REV <b>E</b>
		SCALE: 1:7		DO NOT SCALE		SHEET 1 OF 2	



REVISIONS			
REV.	DESCRIPTION	DATE	BY
E	UPDATED TO CURRENT REVISION	12/9/2019	KC

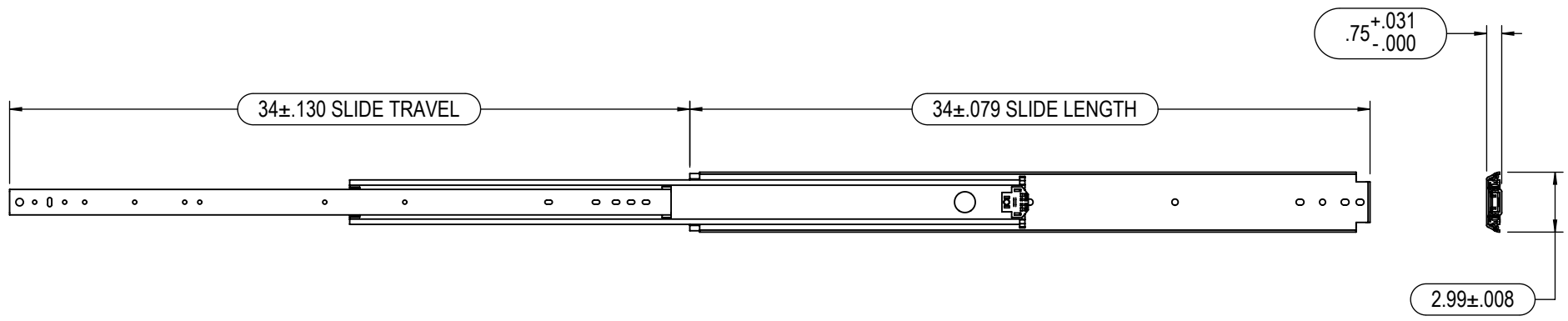



RECOMMENDED  
INNER SLIDE MEMBER:  
#10 MACHINE OR WOOD PAN HEAD SCREW FOR ALL THRU HOLES AND SLOTTED THRU HOLES.

OUTER SLIDE MEMBER:  
1/4 HEX BOLT, #14 PAN HEAD WOOD SCREW FOR ALL THRU HOLES AND SLOTTED THRU HOLES.

SIDE SPACE = .750" - .783"

- NOTES:
1. DIMENSIONS APPLY AFTER FINISH.
  2. DO NOT SCALE DRAWING.
  3. BREAK ALL SHARP EDGES AND REMOVE ALL BURRS.
  4. MUST HAVE NO SCRATCHES, DINGS, DENTS OR SURFACE IMPERFECTIONS OTHER THAN SURFACE FINISH REQUIREMENTS.
  5. CRITICAL DIMENSIONS ARE INDICATED BY:
  6. TO BE INSPECTED TO 2.5 AQL SAMPLING PLAN UNLESS OTHERWISE STATED.
  7. ENSURE PACKAGING WILL PROVIDE ADEQUATE PROTECTION DURING TRANSPORT.
  8. GEOMETRIC FEATURES NOT DIMENSIONED ARE CONTROLLED BY 3D MODEL.

PART NUMBER: <b>I-DS-3300-34</b>		MATERIAL: <b>STEEL</b>		
DESCRIPTION: <b>34" 3300 SERIES SLIDE</b>		FINISH: <b>ZINC PLATED</b>		
				
UNLESS OTHERWISE SPECIFIED: DIMENSIONS ARE IN INCHES [mm]		PROPRIETARY AND CONFIDENTIAL THE INFORMATION CONTAINED IN THIS DRAWING IS THE SOLE PROPERTY OF RYADON INC. ANY REPRODUCTION IN PART OR AS A WHOLE WITHOUT THE WRITTEN PERMISSION OF RYADON INC. IS PROHIBITED.		
THIRD ANGLE PROJECTION 	SIZE <b>A</b>	ENGR	SALES	REV <b>E</b>
		NAME	QUALITY	
		DATE	PN	
SCALE: 1:8		DO NOT SCALE		SHEET 1 OF 2

6 5 4 3 2 1

D

D

C

C

B

B

A

A

6 5 4 3 2 1

D

D

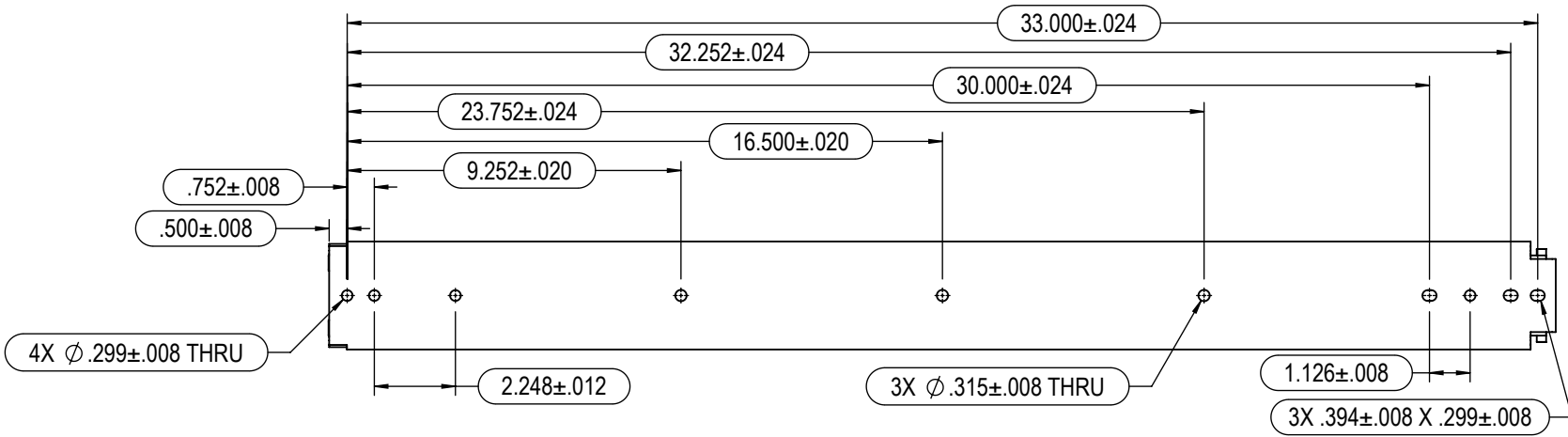

C

C

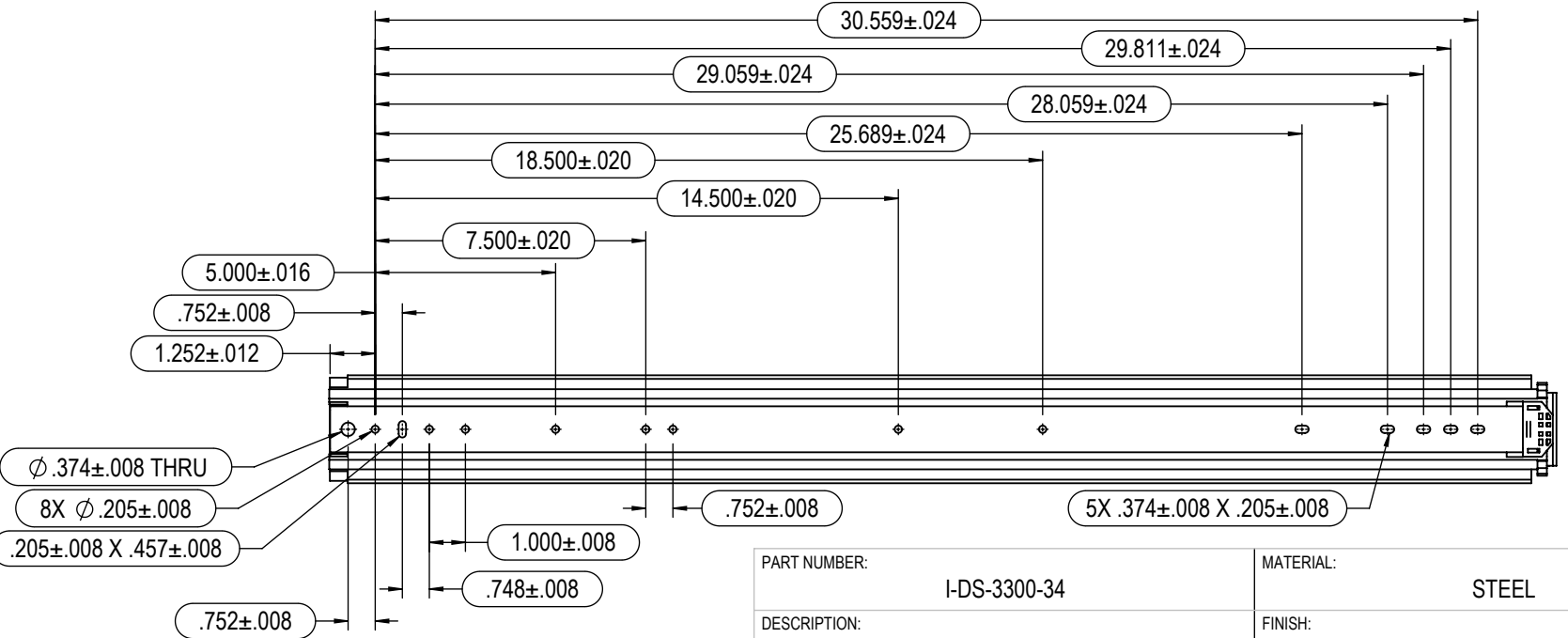

B

B

PART NUMBER: I-DS-3300-34	MATERIAL: STEEL
DESCRIPTION: 34" 3300 SERIES SLIDE	FINISH: ZINC PLATED



# RYADON INC.

UNLESS OTHERWISE SPECIFIED: DIMENSIONS ARE IN INCHES [mm] .XX [X] = ± 0.03 [0.8mm] .XXX [XX] = ± 0.015 [0.38mm] .XXXX [XXX] = ± 0.0080 [0.203mm] FRACTIONAL = ± 1/32" ANGULAR = ± 1.0°	PROPRIETARY AND CONFIDENTIAL THE INFORMATION CONTAINED IN THIS DRAWING IS THE SOLE PROPERTY OF RYADON INC. ANY REPRODUCTION IN PART OR AS A WHOLE WITHOUT THE WRITTEN PERMISSION OF RYADON INC. IS PROHIBITED.					
	THIRD ANGLE PROJECTION 	SIZE <b>A</b>	ENGR KCHEN	SALES	QUALITY	REV <b>E</b>
		DATE 12/10/2019	SCALE: 1:5	DO NOT SCALE	SHEET 2 OF 2	

- NOTES:
1. DIMENSIONS APPLY AFTER FINISH.
  2. DO NOT SCALE DRAWING.
  3. BREAK ALL SHARP EDGES AND REMOVE ALL BURRS.
  4. MUST HAVE NO SCRATCHES, DINGS, DENTS OR SURFACE IMPERFECTIONS OTHER THAN SURFACE FINISH REQUIREMENTS.
  5. CRITICAL DIMENSIONS ARE INDICATED BY:
  6. TO BE INSPECTED TO 2.5 AQL SAMPLING PLAN UNLESS OTHERWISE STATED.
  7. ENSURE PACKAGING WILL PROVIDE ADEQUATE PROTECTION DURING TRANSPORT.
  8. GEOMETRIC FEATURES NOT DIMENSIONED ARE CONTROLLED BY 3D MODEL.

A

A

6

5

4

3

2

1

## REVISIONS

REV.	DESCRIPTION	DATE	BY
E	UPDATED TO CURRENT REVISION	12/9/2019	KC

D

D

C

C

B

B

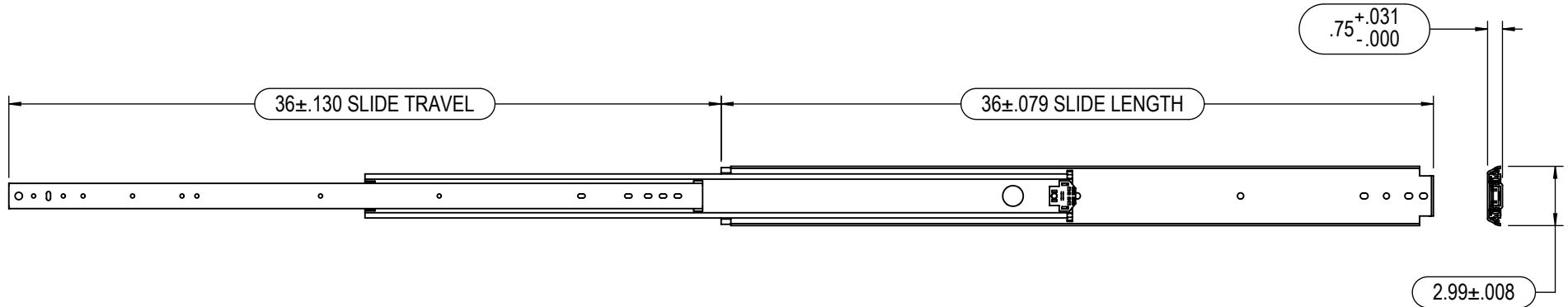

## RECOMMENDED

## INNER SLIDE MEMBER:

#10 MACHINE OR WOOD PAN HEAD SCREW FOR ALL THRU HOLES AND SLOTTED THRU HOLES.

## OUTER SLIDE MEMBER:

1/4 HEX BOLT, #14 PAN HEAD WOOD SCREW FOR ALL THRU HOLES AND SLOTTED THRU HOLES.



SIDE SPACE = .750" - .783"

## NOTES:

1. DIMENSIONS APPLY AFTER FINISH.
2. DO NOT SCALE DRAWING.
3. BREAK ALL SHARP EDGES AND REMOVE ALL BURRS.
4. MUST HAVE NO SCRATCHES, DINGS, DENTS OR SURFACE IMPERFECTIONS OTHER THAN SURFACE FINISH REQUIREMENTS.
5. CRITICAL DIMENSIONS ARE INDICATED BY: 
6. TO BE INSPECTED TO 2.5 AQL SAMPLING PLAN UNLESS OTHERWISE STATED.
7. ENSURE PACKAGING WILL PROVIDE ADEQUATE PROTECTION DURING TRANSPORT.
8. GEOMETRIC FEATURES NOT DIMENSIONED ARE CONTROLLED BY 3D MODEL.

A

A

PART NUMBER: I-DS-3300-36		MATERIAL: STEEL	
DESCRIPTION: 36" 3300 SERIES SLIDE		FINISH: ZINC PLATED	
		<h1>RYADON INC.</h1>	
UNLESS OTHERWISE SPECIFIED: DIMENSIONS ARE IN INCHES [mm]		PROPRIETARY AND CONFIDENTIAL THE INFORMATION CONTAINED IN THIS DRAWING IS THE SOLE PROPERTY OF RYADON INC. ANY REPRODUCTION IN PART OR AS A WHOLE WITHOUT THE WRITTEN PERMISSION OF RYADON INC. IS PROHIBITED.	
THIRD ANGLE PROJECTION 	SIZE <b>A</b>	ENGR	SALES
		KCHEN	BW
		DATE	12/10/2019
SCALE: 1:8		DO NOT SCALE	
		REV <b>E</b>	
		SHEET 1 OF 2	

6

5

4

3

2

1

D

D

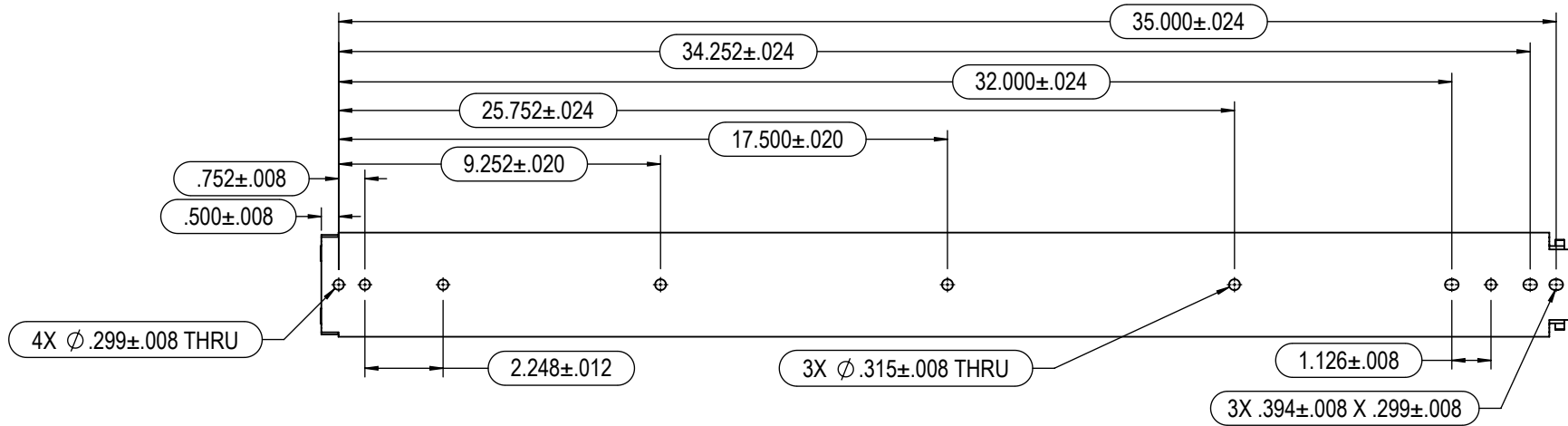

C

C

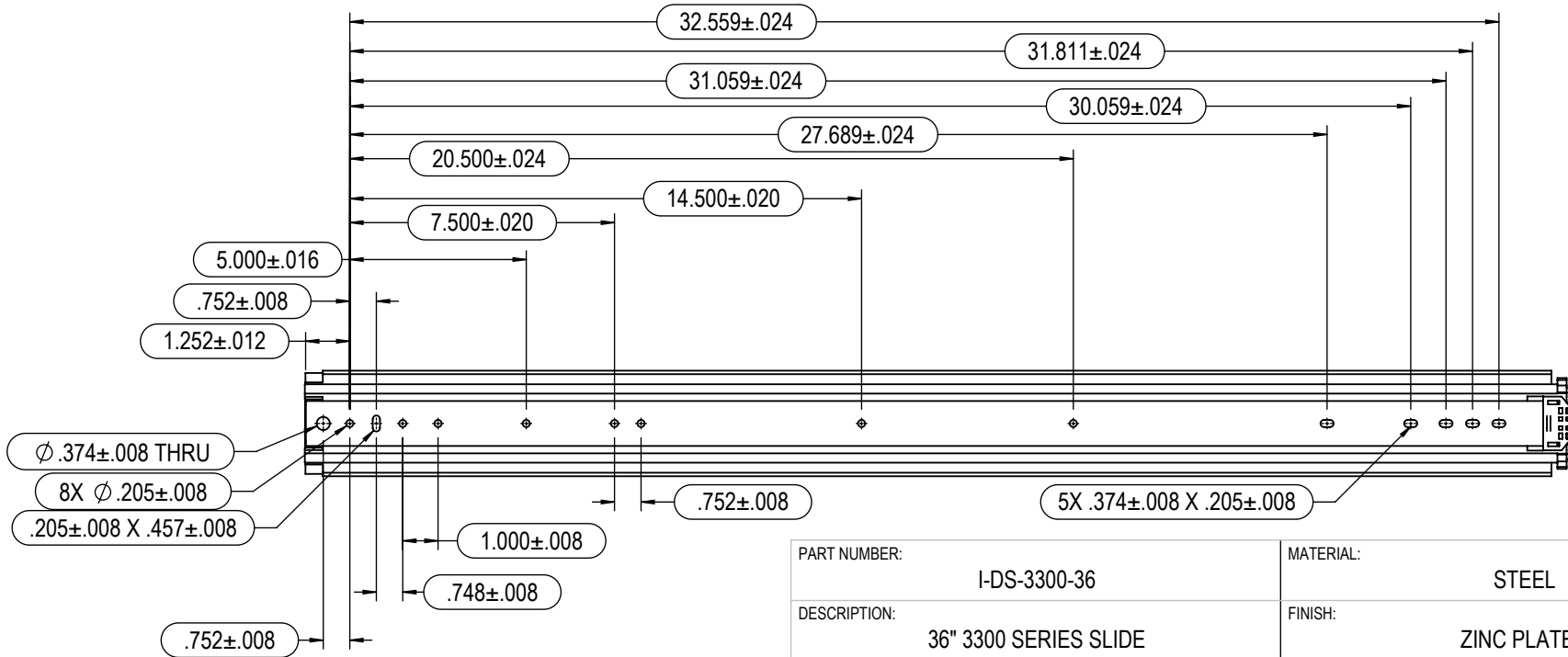

B

B

PART NUMBER:	I-DS-3300-36	MATERIAL:	STEEL
DESCRIPTION:	36" 3300 SERIES SLIDE	FINISH:	ZINC PLATED



# RYADON INC.

UNLESS OTHERWISE SPECIFIED: DIMENSIONS ARE IN INCHES [mm] .XX [X] = ± 0.03 [0.8mm] .XXX [XX] = ± 0.015 [0.38mm] .XXXX [XXX] = ± 0.0080 [0.203mm] FRACTIONAL = ± 1/32" ANGULAR = ± 1.0°	THIRD ANGLE PROJECTION					SIZE <b>A</b>	ENGR	SALES	QUALITY	REV
	NAME		KCHEN				<b>E</b>			
	DATE		12/10/2019							
	SCALE: 1:5		DO NOT SCALE		SHEET 2 OF 2					

- NOTES:
1. DIMENSIONS APPLY AFTER FINISH.
  2. DO NOT SCALE DRAWING.
  3. BREAK ALL SHARP EDGES AND REMOVE ALL BURRS.
  4. MUST HAVE NO SCRATCHES, DINGS, DENTS OR SURFACE IMPERFECTIONS OTHER THAN SURFACE FINISH REQUIREMENTS.
  5. CRITICAL DIMENSIONS ARE INDICATED BY:
  6. TO BE INSPECTED TO 2.5 AQL SAMPLING PLAN UNLESS OTHERWISE STATED.
  7. ENSURE PACKAGING WILL PROVIDE ADEQUATE PROTECTION DURING TRANSPORT.
  8. GEOMETRIC FEATURES NOT DIMENSIONED ARE CONTROLLED BY 3D MODEL.

A

A

6

5

4

3

2

1

## REVISIONS

REV.	DESCRIPTION	DATE	BY
E	UPDATED TO CURRENT REVISION	12/9/2019	KC

D

D

C

C

B

B

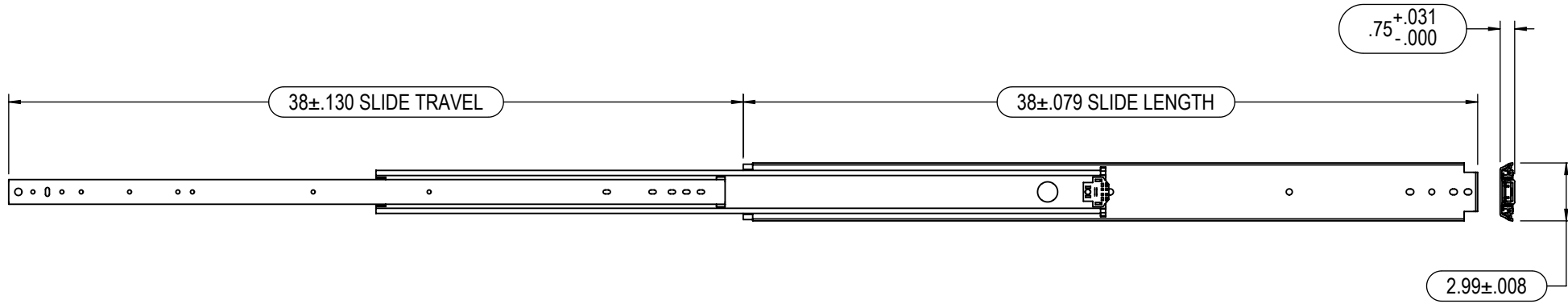

## RECOMMENDED

INNER SLIDE MEMBER:

#10 MACHINE OR WOOD PAN HEAD SCREW FOR ALL THRU HOLES AND SLOTTED THRU HOLES.

OUTER SLIDE MEMBER:

1/4 HEX BOLT, #14 PAN HEAD WOOD SCREW FOR ALL THRU HOLES AND SLOTTED THRU HOLES.



SIDE SPACE = .750" - .783"

## NOTES:

1. DIMENSIONS APPLY AFTER FINISH.
2. DO NOT SCALE DRAWING.
3. BREAK ALL SHARP EDGES AND REMOVE ALL BURRS.
4. MUST HAVE NO SCRATCHES, DINGS, DENTS OR SURFACE IMPERFECTIONS OTHER THAN SURFACE FINISH REQUIREMENTS.
5. CRITICAL DIMENSIONS ARE INDICATED BY: 
6. TO BE INSPECTED TO 2.5 AQL SAMPLING PLAN UNLESS OTHERWISE STATED.
7. ENSURE PACKAGING WILL PROVIDE ADEQUATE PROTECTION DURING TRANSPORT.
8. GEOMETRIC FEATURES NOT DIMENSIONED ARE CONTROLLED BY 3D MODEL.

A

A

PART NUMBER: I-DS-3300-38		MATERIAL: STEEL	
DESCRIPTION: 38" 3300 SERIES SLIDE		FINISH: ZINC PLATED	
		<h1>RYADON INC.</h1>	
UNLESS OTHERWISE SPECIFIED: DIMENSIONS ARE IN INCHES [mm]		PROPRIETARY AND CONFIDENTIAL THE INFORMATION CONTAINED IN THIS DRAWING IS THE SOLE PROPERTY OF RYADON INC. ANY REPRODUCTION IN PART OR AS A WHOLE WITHOUT THE WRITTEN PERMISSION OF RYADON INC. IS PROHIBITED.	
THIRD ANGLE PROJECTION 	SIZE <b>A</b>	ENGR	SALES
		KCHEN	BW
		DATE	12/10/2019
SCALE: 1:8		DO NOT SCALE	
		REV <b>E</b>	
		SHEET 1 OF 2	

6

5

4



3

2

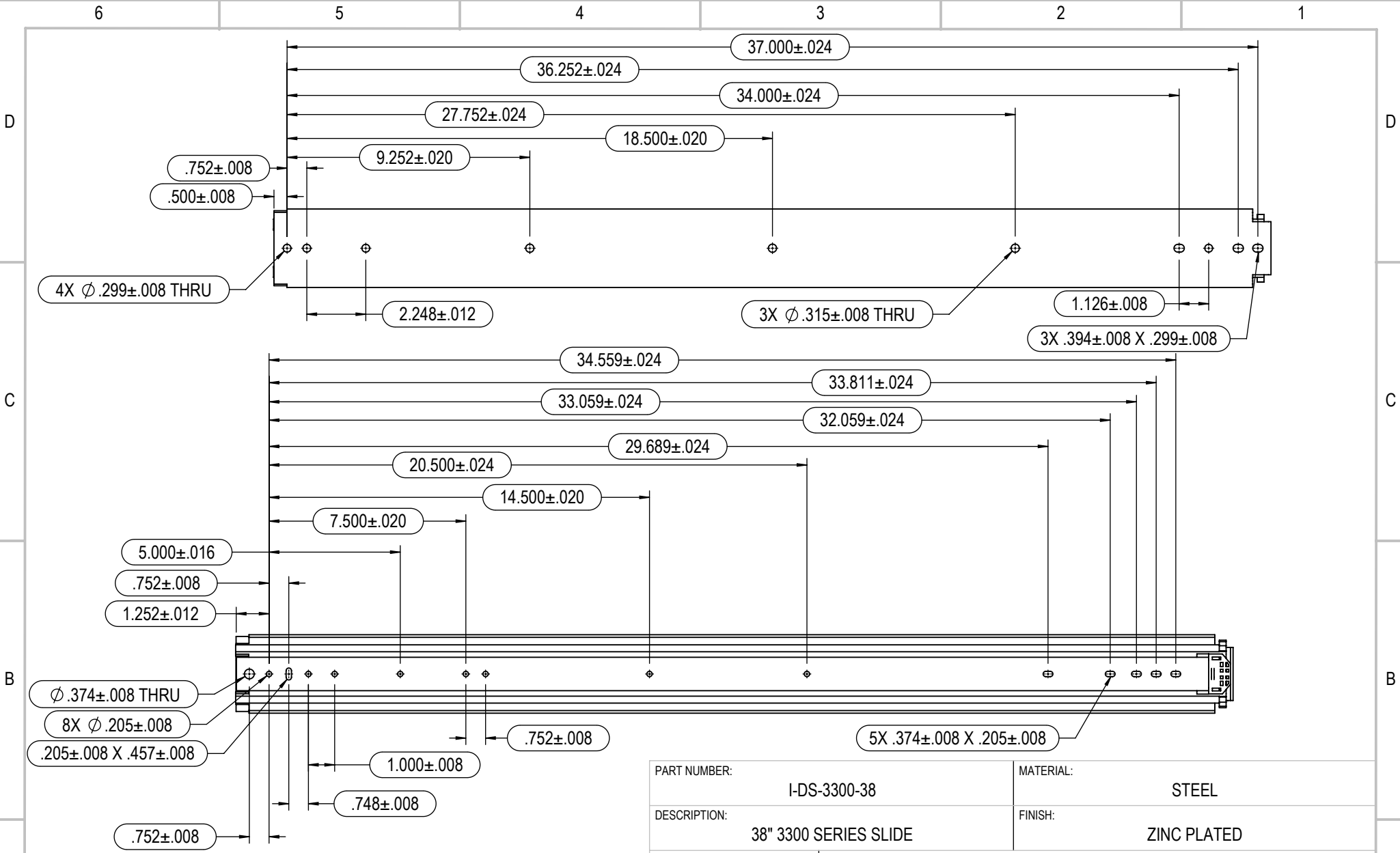
1



- NOTES:
1. DIMENSIONS APPLY AFTER FINISH.
  2. DO NOT SCALE DRAWING.
  3. BREAK ALL SHARP EDGES AND REMOVE ALL BURRS.
  4. MUST HAVE NO SCRATCHES, DINGS, DENTS OR SURFACE IMPERFECTIONS OTHER THAN SURFACE FINISH REQUIREMENTS.
  5. CRITICAL DIMENSIONS ARE INDICATED BY:
  6. TO BE INSPECTED TO 2.5 AQL SAMPLING PLAN UNLESS OTHERWISE STATED.
  7. ENSURE PACKAGING WILL PROVIDE ADEQUATE PROTECTION DURING TRANSPORT.
  8. GEOMETRIC FEATURES NOT DIMENSIONED ARE CONTROLLED BY 3D MODEL.

PART NUMBER: I-DS-3300-38		MATERIAL: STEEL																	
DESCRIPTION: 38" 3300 SERIES SLIDE		FINISH: ZINC PLATED																	
		<h1>RYADON INC.</h1>																	
UNLESS OTHERWISE SPECIFIED: DIMENSIONS ARE IN INCHES [mm]		<small>PROPRIETARY AND CONFIDENTIAL</small> THE INFORMATION CONTAINED IN THIS DRAWING IS THE SOLE PROPERTY OF RYADON INC. ANY REPRODUCTION IN PART OR AS A WHOLE WITHOUT THE WRITTEN PERMISSION OF RYADON INC. IS PROHIBITED.																	
<small>XX [X] = ± 0.03 [0.8mm]          .XXX [XX] = ± 0.015 [0.38mm]          .XXXX [XXX] = ± 0.0080 [0.203mm]          FRACTIONAL = ± 1/32"          ANGULAR = ± 1.0°</small>	<small>THIRD ANGLE PROJECTION</small> 	<b>SIZE</b> <span style="font-size: 2em; font-weight: bold;">A</span>	<table border="1"> <tr> <td>ENGR</td> <td>SALES</td> <td>QUALITY</td> <td>REV</td> </tr> <tr> <td>KCHEN</td> <td></td> <td></td> <td><b>E</b></td> </tr> <tr> <td>DATE</td> <td>12/10/2019</td> <td></td> <td></td> </tr> <tr> <td colspan="2">SCALE: 1:5</td> <td>DO NOT SCALE</td> <td>SHEET 2 OF 2</td> </tr> </table>	ENGR	SALES	QUALITY	REV	KCHEN			<b>E</b>	DATE	12/10/2019			SCALE: 1:5		DO NOT SCALE	SHEET 2 OF 2
	ENGR	SALES	QUALITY	REV															
	KCHEN			<b>E</b>															
DATE	12/10/2019																		
SCALE: 1:5		DO NOT SCALE	SHEET 2 OF 2																



6

5

4

3

2

1

## REVISIONS

REV.	DESCRIPTION	DATE	BY
E	UPDATED TO CURRENT REVISION	12/9/2019	KC

D

D

C

C

B

B

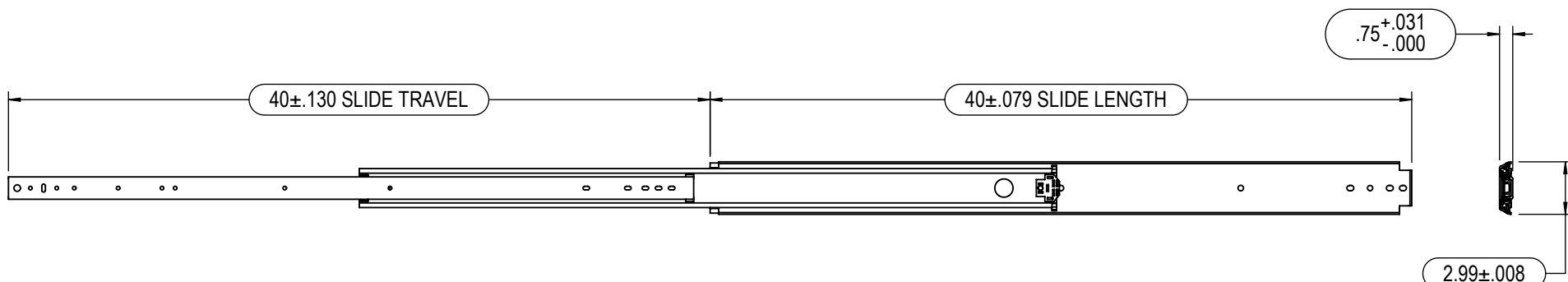

## RECOMMENDED

## INNER SLIDE MEMBER:

#10 MACHINE OR WOOD PAN HEAD SCREW FOR ALL THRU HOLES AND SLOTTED THRU HOLES.

## OUTER SLIDE MEMBER:

1/4 HEX BOLT, #14 PAN HEAD WOOD SCREW FOR ALL THRU HOLES AND SLOTTED THRU HOLES.

SIDE SPACE = .750" - .783"

## NOTES:

1. DIMENSIONS APPLY AFTER FINISH.
2. DO NOT SCALE DRAWING.
3. BREAK ALL SHARP EDGES AND REMOVE ALL BURRS.
4. MUST HAVE NO SCRATCHES, DINGS, DENTS OR SURFACE IMPERFECTIONS OTHER THAN SURFACE FINISH REQUIREMENTS.
5. CRITICAL DIMENSIONS ARE INDICATED BY: 
6. TO BE INSPECTED TO 2.5 AQL SAMPLING PLAN UNLESS OTHERWISE STATED.
7. ENSURE PACKAGING WILL PROVIDE ADEQUATE PROTECTION DURING TRANSPORT.
8. GEOMETRIC FEATURES NOT DIMENSIONED ARE CONTROLLED BY 3D MODEL.

A

A

PART NUMBER:

I-DS-3300-40

MATERIAL:

STEEL

DESCRIPTION:

40" 3300 SERIES SLIDE

FINISH:

ZINC PLATED



# RYADON INC.

UNLESS OTHERWISE SPECIFIED:

DIMENSIONS ARE IN INCHES [mm]

.XX [X] = ± 0.03 [0.8mm]  
 .XXX [XX] = ± 0.015 [0.38mm]  
 .XXXX [XXX] = ± 0.0080 [0.203mm]  
 FRACTIONAL = ± 1/32"  
 ANGULAR: ± 1.0°

THIRD ANGLE PROJECTION



SIZE

## A

PROPRIETARY AND CONFIDENTIAL  
 THE INFORMATION CONTAINED IN THIS DRAWING IS THE SOLE PROPERTY OF RYADON INC. ANY REPRODUCTION  
 IN PART OR AS A WHOLE WITHOUT THE WRITTEN PERMISSION OF RYADON INC. IS PROHIBITED.

NAME	ENGR	SALES	QUALITY	REV
KCHEN	BW	PN		E
DATE	12/10/2019	1/17/2020	12/20/2019	
SCALE: 1:9		DO NOT SCALE		SHEET 1 OF 2

6

5

4

3

2

1

6 5 4 3 2 1

D

D

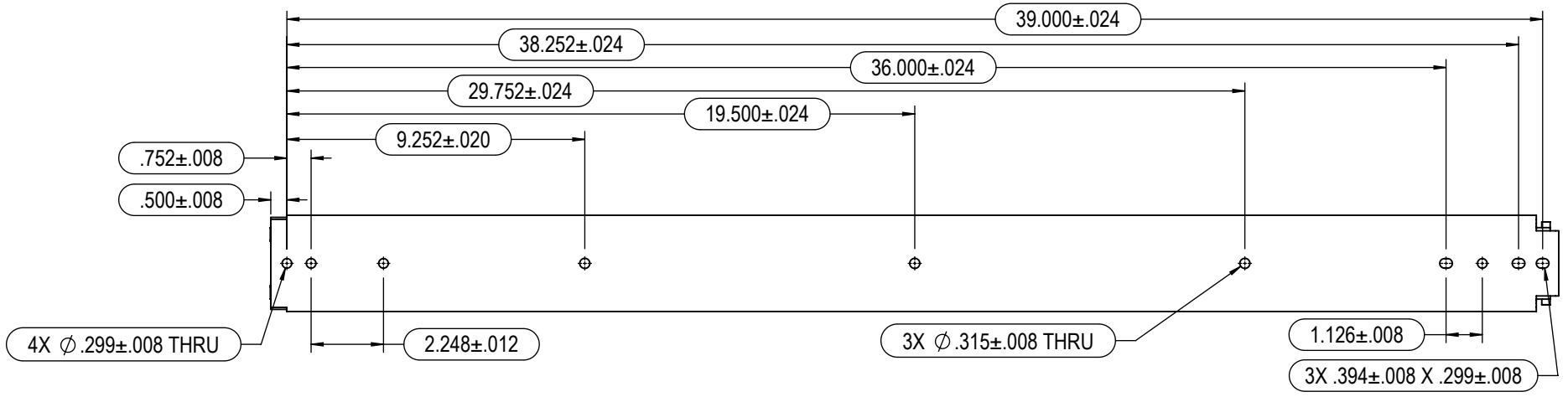

C

C

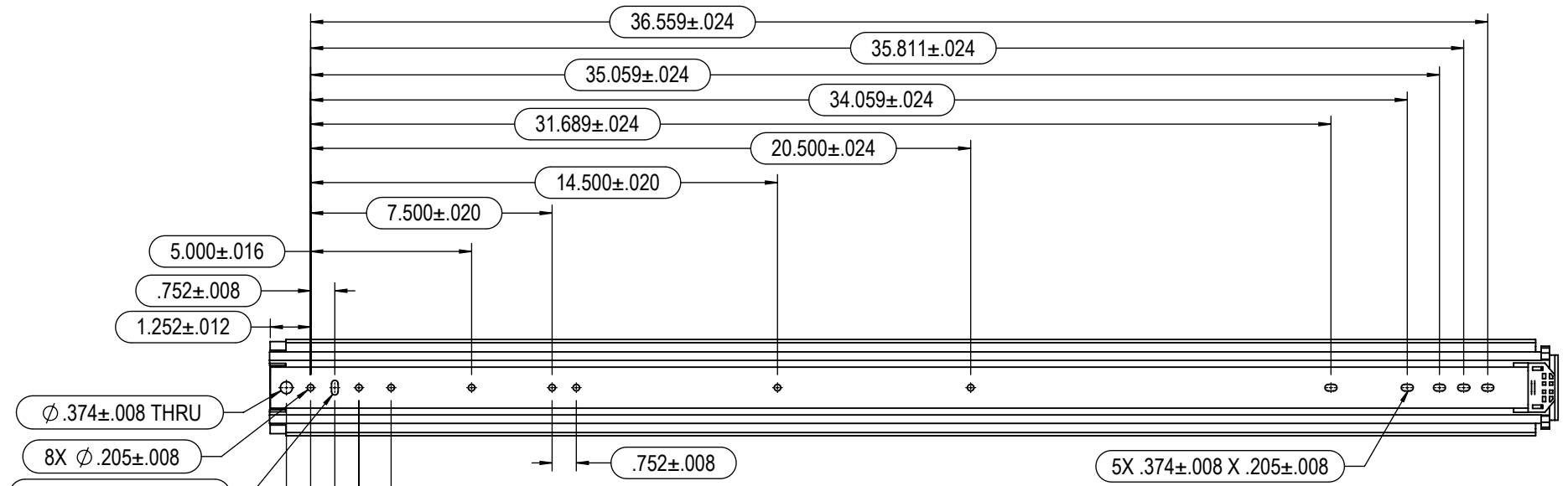

B

B

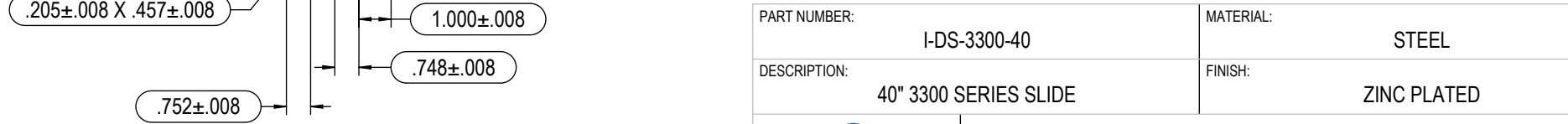

A

A

- NOTES:
1. DIMENSIONS APPLY AFTER FINISH.
  2. DO NOT SCALE DRAWING.
  3. BREAK ALL SHARP EDGES AND REMOVE ALL BURRS.
  4. MUST HAVE NO SCRATCHES, DINGS, DENTS OR SURFACE IMPERFECTIONS OTHER THAN SURFACE FINISH REQUIREMENTS.
  5. CRITICAL DIMENSIONS ARE INDICATED BY:
  6. TO BE INSPECTED TO 2.5 AQL SAMPLING PLAN UNLESS OTHERWISE STATED.
  7. ENSURE PACKAGING WILL PROVIDE ADEQUATE PROTECTION DURING TRANSPORT.
  8. GEOMETRIC FEATURES NOT DIMENSIONED ARE CONTROLLED BY 3D MODEL.

PART NUMBER:	I-DS-3300-40	MATERIAL:	STEEL
DESCRIPTION:	40" 3300 SERIES SLIDE	FINISH:	ZINC PLATED



# RYADON INC.

UNLESS OTHERWISE SPECIFIED: DIMENSIONS ARE IN INCHES [mm] .XX [X] = ± 0.03 [0.8mm] .XXX [XX] = ± 0.015 [0.38mm] .XXXX [XXX] = ± 0.0080 [0.203mm] FRACTIONAL = ± 1/32" ANGULAR = ± 1.0°	PROPRIETARY AND CONFIDENTIAL THE INFORMATION CONTAINED IN THIS DRAWING IS THE SOLE PROPERTY OF RYADON INC. ANY REPRODUCTION IN PART OR AS A WHOLE WITHOUT THE WRITTEN PERMISSION OF RYADON INC. IS PROHIBITED.				
	THIRD ANGLE PROJECTION	SIZE	ENGR	SALES	QUALITY
		<b>A</b>	KCHEN		
		DATE	12/10/2019		<b>E</b>
		SCALE: 1:5	DO NOT SCALE	SHEET 2 OF 2	

6 5 4 3 2 1

REVISIONS			
REV.	DESCRIPTION	DATE	BY
E	UPDATED TO CURRENT REVISION	12/10/2019	KC

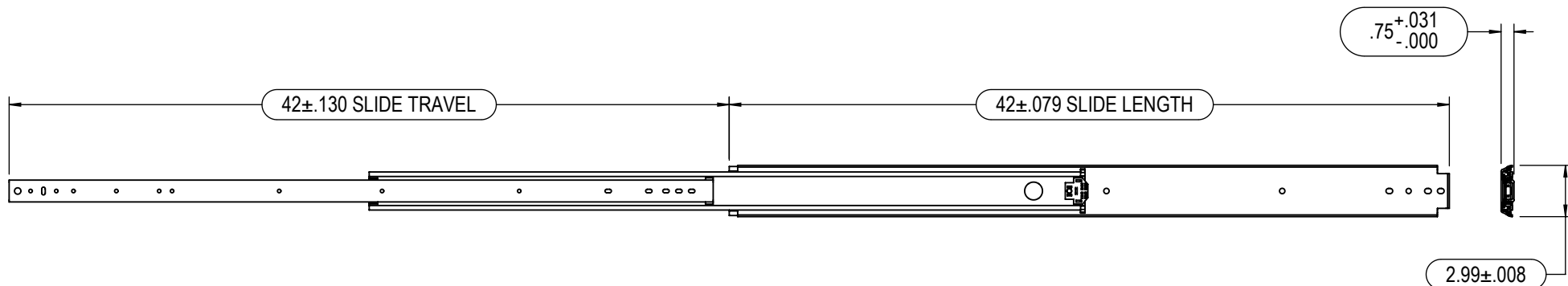



RECOMMENDED  
INNER SLIDE MEMBER:  
#10 MACHINE OR WOOD PAN HEAD SCREW FOR ALL THRU HOLES AND SLOTTED THRU HOLES.

OUTER SLIDE MEMBER:  
1/4 HEX BOLT, #14 PAN HEAD WOOD SCREW FOR ALL THRU HOLES AND SLOTTED THRU HOLES.

SIDE SPACE = .750" - .783"

- NOTES:
1. DIMENSIONS APPLY AFTER FINISH.
  2. DO NOT SCALE DRAWING.
  3. BREAK ALL SHARP EDGES AND REMOVE ALL BURRS.
  4. MUST HAVE NO SCRATCHES, DINGS, DENTS OR SURFACE IMPERFECTIONS OTHER THAN SURFACE FINISH REQUIREMENTS.
  5. CRITICAL DIMENSIONS ARE INDICATED BY:
  6. TO BE INSPECTED TO 2.5 AQL SAMPLING PLAN UNLESS OTHERWISE STATED.
  7. ENSURE PACKAGING WILL PROVIDE ADEQUATE PROTECTION DURING TRANSPORT.
  8. GEOMETRIC FEATURES NOT DIMENSIONED ARE CONTROLLED BY 3D MODEL.

PART NUMBER: <b>I-DS-3300-42</b>		MATERIAL: <b>STEEL</b>					
DESCRIPTION: <b>42" 3300 SERIES SLIDE</b>		FINISH: <b>ZINC PLATED</b>					
		<h1>RYADON INC.</h1>					
UNLESS OTHERWISE SPECIFIED: DIMENSIONS ARE IN INCHES [mm]		<small>PROPRIETARY AND CONFIDENTIAL</small> THE INFORMATION CONTAINED IN THIS DRAWING IS THE SOLE PROPERTY OF RYADON INC. ANY REPRODUCTION IN PART OR AS A WHOLE WITHOUT THE WRITTEN PERMISSION OF RYADON INC. IS PROHIBITED.					
<small>.XX [X] = ± 0.03 [0.8mm]          .XXX [XX] = ± 0.015 [0.38mm]          .XXXX [XXX] = ± 0.0080 [0.203mm]          FRACTIONAL = ± 1/32"          ANGULAR: ± 1.0°</small>	<small>THIRD ANGLE PROJECTION</small> 		<b>SIZE</b>  <span style="font-size: 2em; font-weight: bold;">A</span>	ENGR	SALES	QUALITY	REV
	NAME	KCHEN		BW	PN	E	
	DATE	12/10/2019		1/17/2020	12/20/2019		
SCALE: 1:9			DO NOT SCALE		SHEET 1 OF 2		

6 5 4 3 2 1

D

C

B

A

D

C

B

A

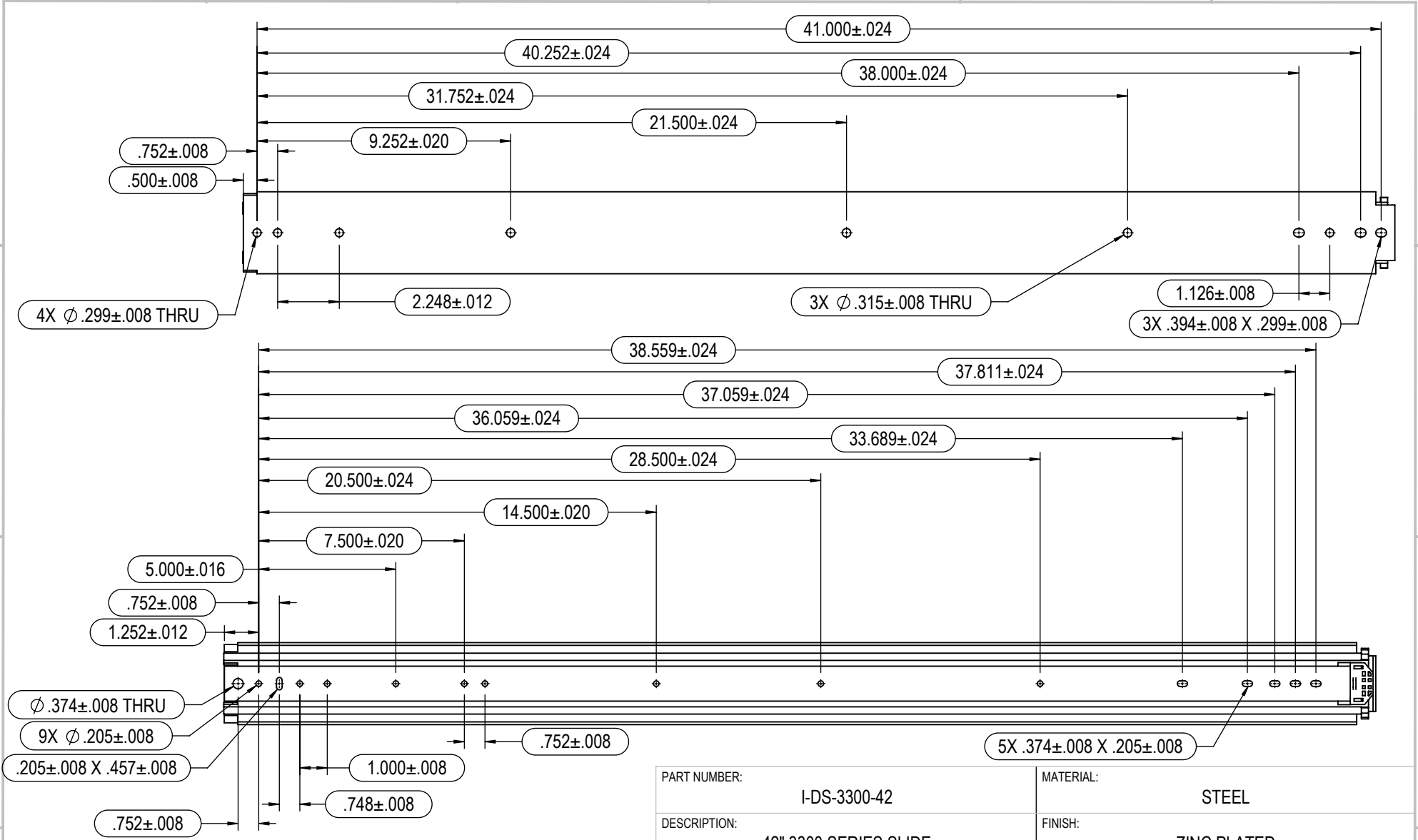

PART NUMBER:	I-DS-3300-42	MATERIAL:	STEEL
DESCRIPTION:	42" 3300 SERIES SLIDE	FINISH:	ZINC PLATED



# RYADON INC.

UNLESS OTHERWISE SPECIFIED: DIMENSIONS ARE IN INCHES [mm] .XX [X] = ± 0.03 [0.8mm] .XXX [XX] = ± 0.015 [0.38mm] .XXXX [XXX] = ± 0.0080 [0.203mm] FRACTIONAL = ± 1/32" ANGULAR: ± 1.0°	THIRD ANGLE PROJECTION					SIZE <b>A</b>	ENGR	SALES	QUALITY	REV
	NAME		KCHEN				<b>E</b>			
	DATE		12/10/2019							
	SCALE: 1:5		DO NOT SCALE		SHEET 2 OF 2					

- NOTES:
1. DIMENSIONS APPLY AFTER FINISH.
  2. DO NOT SCALE DRAWING.
  3. BREAK ALL SHARP EDGES AND REMOVE ALL BURRS.
  4. MUST HAVE NO SCRATCHES, DINGS, DENTS OR SURFACE IMPERFECTIONS OTHER THAN SURFACE FINISH REQUIREMENTS.
  5. CRITICAL DIMENSIONS ARE INDICATED BY:
  6. TO BE INSPECTED TO 2.5 AQL SAMPLING PLAN UNLESS OTHERWISE STATED.
  7. ENSURE PACKAGING WILL PROVIDE ADEQUATE PROTECTION DURING TRANSPORT.
  8. GEOMETRIC FEATURES NOT DIMENSIONED ARE CONTROLLED BY 3D MODEL.

6 5 4 3 2 1

REVISIONS			
REV.	DESCRIPTION	DATE	BY
E	UPDATED TO CURRENT REVISION	12/10/2019	KC

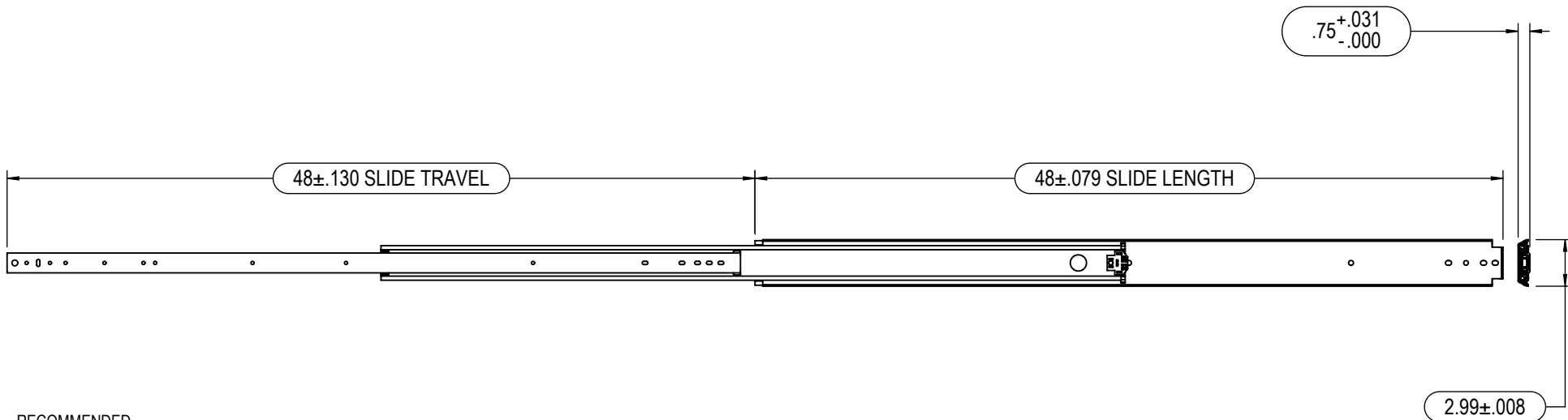



RECOMMENDED  
INNER SLIDE MEMBER:  
#10 MACHINE OR WOOD PAN HEAD SCREW FOR ALL THRU HOLES AND SLOTTED THRU HOLES.

OUTER SLIDE MEMBER:  
1/4 HEX BOLT, #14 PAN HEAD WOOD SCREW FOR ALL THRU HOLES AND SLOTTED THRU HOLES.

SIDE SPACE = .750" - .783"

- NOTES:
1. DIMENSIONS APPLY AFTER FINISH.
  2. DO NOT SCALE DRAWING.
  3. BREAK ALL SHARP EDGES AND REMOVE ALL BURRS.
  4. MUST HAVE NO SCRATCHES, DINGS, DENTS OR SURFACE IMPERFECTIONS OTHER THAN SURFACE FINISH REQUIREMENTS.
  5. CRITICAL DIMENSIONS ARE INDICATED BY:
  6. TO BE INSPECTED TO 2.5 AQL SAMPLING PLAN UNLESS OTHERWISE STATED.
  7. ENSURE PACKAGING WILL PROVIDE ADEQUATE PROTECTION DURING TRANSPORT.
  8. GEOMETRIC FEATURES NOT DIMENSIONED ARE CONTROLLED BY 3D MODEL.

PART NUMBER: I-DS-3300-48		MATERIAL: STEEL			
DESCRIPTION: 48" 3300 SERIES SLIDE		FINISH: ZINC PLATED			
 9001:2015		<h1>RYADON INC.</h1>			
UNLESS OTHERWISE SPECIFIED: DIMENSIONS ARE IN INCHES [mm]		PROPRIETARY AND CONFIDENTIAL THE INFORMATION CONTAINED IN THIS DRAWING IS THE SOLE PROPERTY OF RYADON INC. ANY REPRODUCTION IN PART OR AS A WHOLE WITHOUT THE WRITTEN PERMISSION OF RYADON INC. IS PROHIBITED.			
THIRD ANGLE PROJECTION 	SIZE <b>A</b>	ENGR	SALES	QUALITY	REV <b>E</b>
		KCHEN	BW	PN	
		DATE	12/10/2019	1/17/2020	
SCALE: 1:10		DO NOT SCALE		SHEET 1 OF 2	

UNLESS OTHERWISE SPECIFIED:  
DIMENSIONS ARE IN INCHES [mm]

.XX [X] = ± 0.03 [0.8mm]  
 .XXX [XX] = ± 0.015 [0.38mm]  
 .XXXX [XXX] = ± 0.0080 [0.203mm]  
 FRACTIONAL = ± 1/32"  
 ANGULAR: ± 1.0°

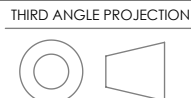

**A**

ENGR	SALES	QUALITY	REV <b>E</b>
KCHEN	BW	PN	
DATE	12/10/2019	1/17/2020	
SCALE: 1:10		DO NOT SCALE	
			SHEET 1 OF 2

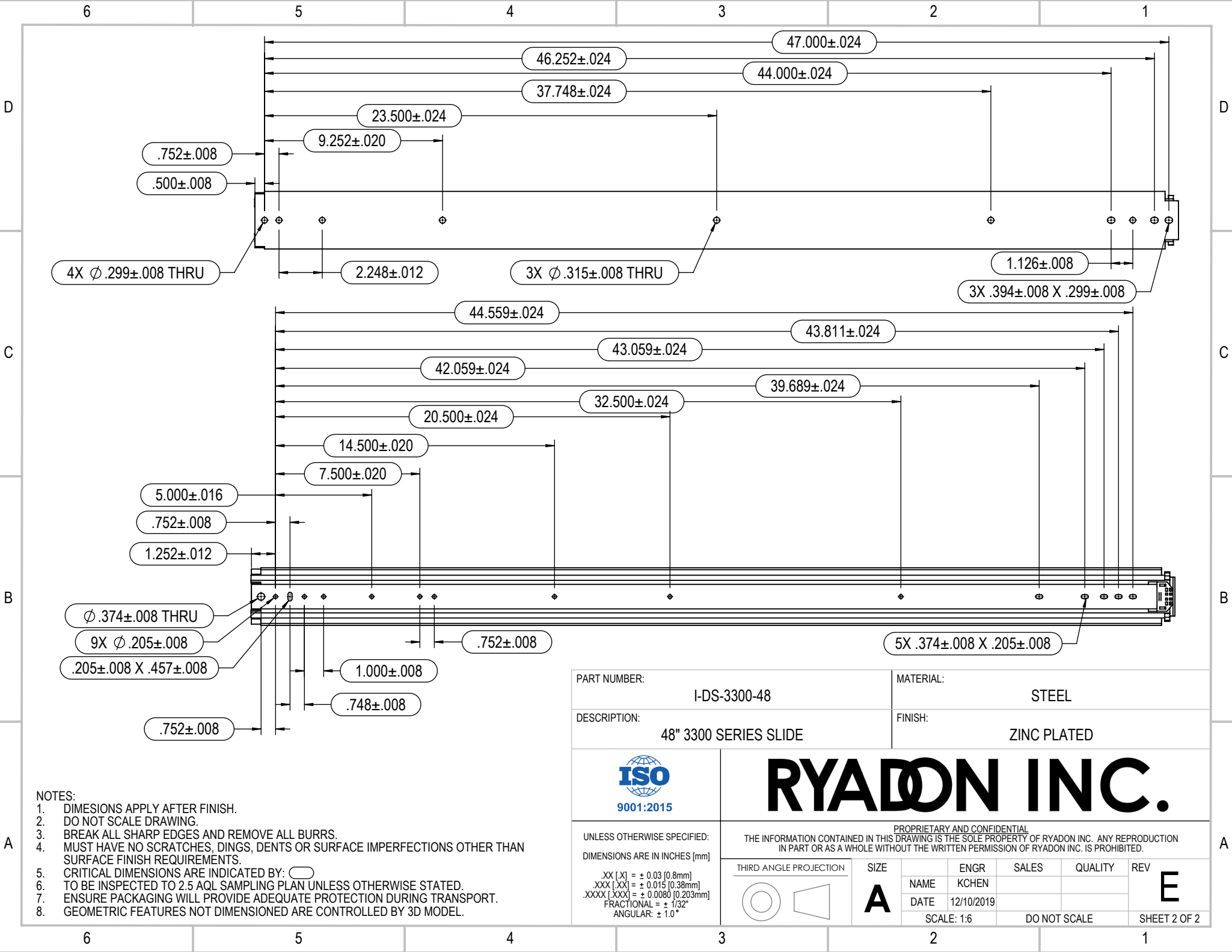

PART NUMBER: I-DS-3300-48	MATERIAL: STEEL
DESCRIPTION: 48" 3300 SERIES SLIDE	FINISH: ZINC PLATED



UNLESS OTHERWISE SPECIFIED: DIMENSIONS ARE IN INCHES [mm] .XX [X] = ± 0.03 [0.8mm] .XXX [XX] = ± 0.015 [0.38mm] .XXXX [XXX] = ± 0.0080 [0.203mm] FRACTIONAL = ± 1/32" ANGULAR = ± 1.0°	THIRD ANGLE PROJECTION					PROPRIETARY AND CONFIDENTIAL THE INFORMATION CONTAINED IN THIS DRAWING IS THE SOLE PROPERTY OF RYADON INC. ANY REPRODUCTION IN PART OR AS A WHOLE WITHOUT THE WRITTEN PERMISSION OF RYADON INC. IS PROHIBITED.				
		SIZE	ENGR	SALES	QUALITY	REV				
		<b>A</b>	KCHEN							
	DATE	SCALE: 1:6	DO NOT SCALE	SHEET 2 OF 2						

- NOTES:
1. DIMENSIONS APPLY AFTER FINISH.
  2. DO NOT SCALE DRAWING.
  3. BREAK ALL SHARP EDGES AND REMOVE ALL BURRS.
  4. MUST HAVE NO SCRATCHES, DINGS, DENTS OR SURFACE IMPERFECTIONS OTHER THAN SURFACE FINISH REQUIREMENTS.
  5. CRITICAL DIMENSIONS ARE INDICATED BY:
  6. TO BE INSPECTED TO 2.5 AQL SAMPLING PLAN UNLESS OTHERWISE STATED.
  7. ENSURE PACKAGING WILL PROVIDE ADEQUATE PROTECTION DURING TRANSPORT.
  8. GEOMETRIC FEATURES NOT DIMENSIONED ARE CONTROLLED BY 3D MODEL.

REVISIONS			
REV.	DESCRIPTION	DATE	BY
E	UPDATED TO CURRENT REVISION	12/10/2019	KC

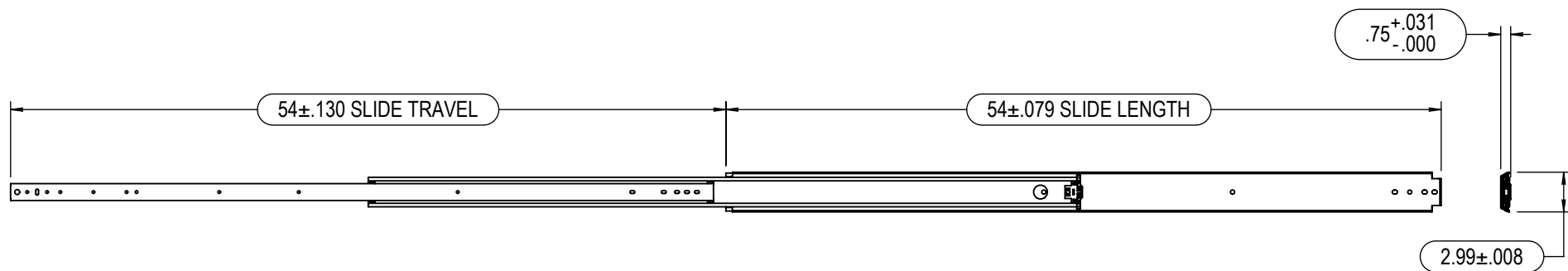



RECOMMENDED  
 INNER SLIDE MEMBER:  
 #10 MACHINE OR WOOD PAN HEAD SCREW FOR ALL THRU HOLES AND SLOTTED THRU HOLES.

OUTER SLIDE MEMBER:  
 1/4 HEX BOLT, #14 PAN HEAD WOOD SCREW FOR ALL THRU HOLES AND SLOTTED THRU HOLES.

SIDE SPACE = .750" - .783"

- NOTES:
1. DIMENSIONS APPLY AFTER FINISH.
  2. DO NOT SCALE DRAWING.
  3. BREAK ALL SHARP EDGES AND REMOVE ALL BURRS.
  4. MUST HAVE NO SCRATCHES, DINGS, DENTS OR SURFACE IMPERFECTIONS OTHER THAN SURFACE FINISH REQUIREMENTS.
  5. CRITICAL DIMENSIONS ARE INDICATED BY:
  6. TO BE INSPECTED TO 2.5 AQL SAMPLING PLAN UNLESS OTHERWISE STATED.
  7. ENSURE PACKAGING WILL PROVIDE ADEQUATE PROTECTION DURING TRANSPORT.
  8. GEOMETRIC FEATURES NOT DIMENSIONED ARE CONTROLLED BY 3D MODEL.

PART NUMBER: I-DS-3300-54		MATERIAL: STEEL			
DESCRIPTION: 54" 3300 SERIES SLIDE		FINISH: ZINC PLATED			
 <b>RYADON INC.</b>		<b>RYADON INC.</b>			
UNLESS OTHERWISE SPECIFIED: DIMENSIONS ARE IN INCHES [mm]		<small>PROPRIETARY AND CONFIDENTIAL</small> THE INFORMATION CONTAINED IN THIS DRAWING IS THE SOLE PROPERTY OF RYADON INC. ANY REPRODUCTION IN PART OR AS A WHOLE WITHOUT THE WRITTEN PERMISSION OF RYADON INC. IS PROHIBITED.			
<small>THIRD ANGLE PROJECTION</small> 	<b>SIZE</b> <b>A</b>	ENGR	SALES	QUALITY	<b>REV</b> <b>E</b>
		NAME	BW	PN	
		DATE	1/17/2020	12/20/2019	
<small>.XX [X] = ± 0.03 [0.8mm]          .XXX [XX] = ± 0.015 [0.38mm]          .XXXX [XXX] = ± 0.0080 [0.203mm]          FRACTIONAL = ± 1/32"          ANGULAR: ± 1.0°</small>		SCALE: 1:12	DO NOT SCALE		SHEET 1 OF 2





6

5

4

3

2

1

## REVISIONS

REV.	DESCRIPTION	DATE	BY
E	UPDATED TO CURRENT REVISION	12/10/2019	KC

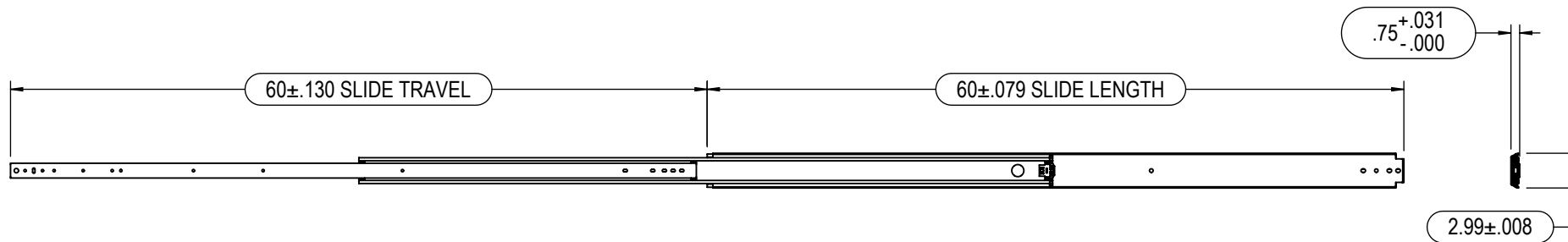

## RECOMMENDED

INNER SLIDE MEMBER:

#10 MACHINE OR WOOD PAN HEAD SCREW FOR ALL THRU HOLES AND SLOTTED THRU HOLES.

OUTER SLIDE MEMBER:

1/4 HEX BOLT, #14 PAN HEAD WOOD SCREW FOR ALL THRU HOLES AND SLOTTED THRU HOLES.

SIDE SPACE = .750" - .783"

## NOTES:

1. DIMENSIONS APPLY AFTER FINISH.
2. DO NOT SCALE DRAWING.
3. BREAK ALL SHARP EDGES AND REMOVE ALL BURRS.
4. MUST HAVE NO SCRATCHES, DINGS, DENTS OR SURFACE IMPERFECTIONS OTHER THAN SURFACE FINISH REQUIREMENTS.
5. CRITICAL DIMENSIONS ARE INDICATED BY:
6. TO BE INSPECTED TO 2.5 AQL SAMPLING PLAN UNLESS OTHERWISE STATED.
7. ENSURE PACKAGING WILL PROVIDE ADEQUATE PROTECTION DURING TRANSPORT.
8. GEOMETRIC FEATURES NOT DIMENSIONED ARE CONTROLLED BY 3D MODEL.

PART NUMBER:

I-DS-3300-60

MATERIAL:

STEEL

DESCRIPTION:

60" 3300 SERIES SLIDE

FINISH:

ZINC PLATED



# RYADON INC.

UNLESS OTHERWISE SPECIFIED:

DIMENSIONS ARE IN INCHES [mm]

.XX [X] = ± 0.03 [0.8mm]  
 .XXX [XX] = ± 0.015 [0.38mm]  
 .XXXX [XXX] = ± 0.0080 [0.203mm]  
 FRACTIONAL = ± 1/32"  
 ANGULAR: ± 1.0°

THIRD ANGLE PROJECTION



SIZE

## A

PROPRIETARY AND CONFIDENTIAL  
 THE INFORMATION CONTAINED IN THIS DRAWING IS THE SOLE PROPERTY OF RYADON INC. ANY REPRODUCTION  
 IN PART OR AS A WHOLE WITHOUT THE WRITTEN PERMISSION OF RYADON INC. IS PROHIBITED.

NAME	ENGR	SALES	QUALITY	REV
KCHEN	BW	PN		E
DATE	12/10/2019	1/17/2020	12/20/2019	
SCALE:	1:14	DO NOT SCALE		SHEET 1 OF 2

6

5

4

3

2

1

D

D

C

C

B

B

A

A

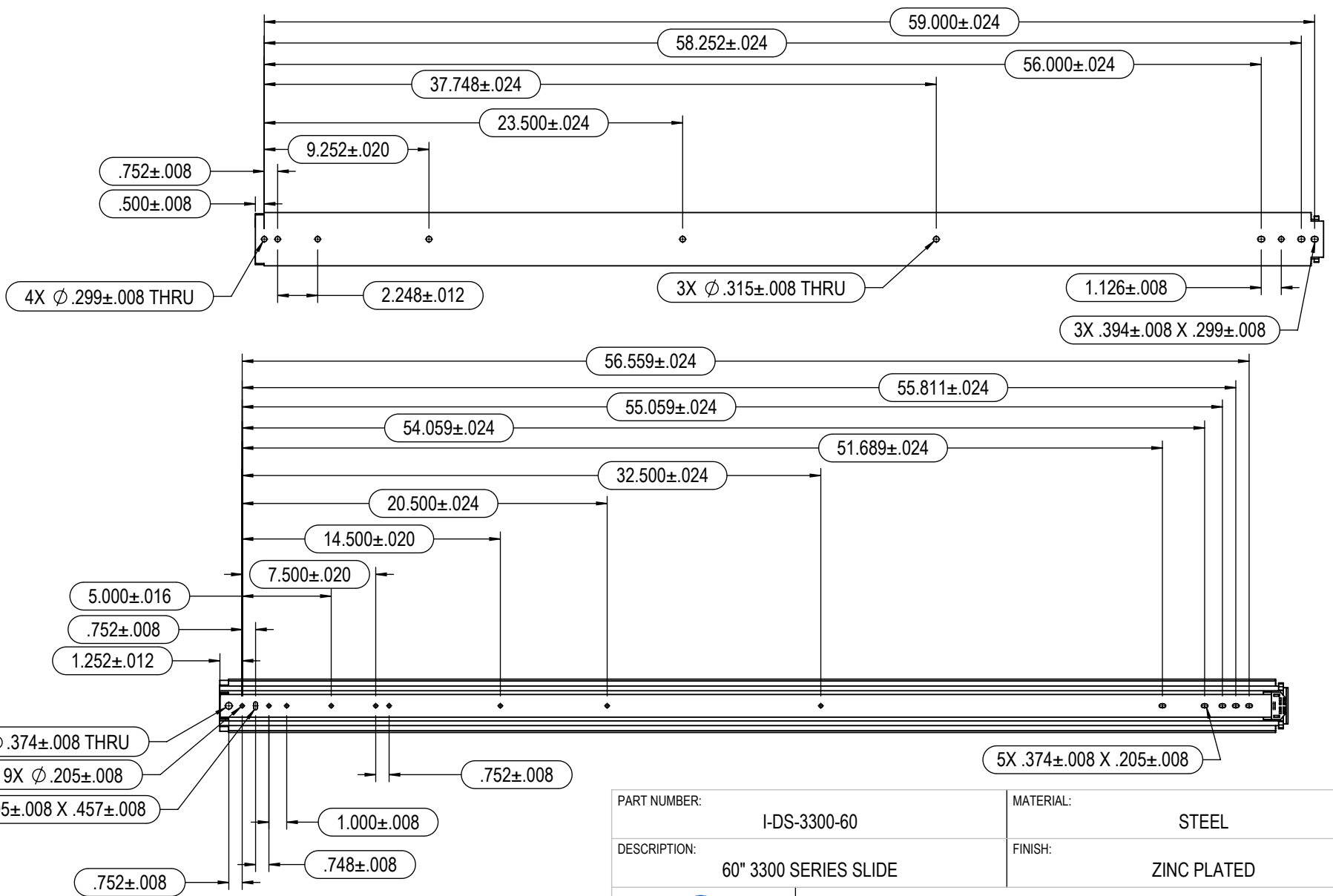

PART NUMBER: I-DS-3300-60	MATERIAL: STEEL
DESCRIPTION: 60" 3300 SERIES SLIDE	FINISH: ZINC PLATED



# RYADON INC.

UNLESS OTHERWISE SPECIFIED: DIMENSIONS ARE IN INCHES [mm] .XX [X] = ± 0.03 [0.8mm] .XXX [XX] = ± 0.015 [0.38mm] .XXXX [XXX] = ± 0.0080 [0.203mm] FRACTIONAL = ± 1/32" ANGULAR = ± 1.0°	PROPRIETARY AND CONFIDENTIAL THE INFORMATION CONTAINED IN THIS DRAWING IS THE SOLE PROPERTY OF RYADON INC. ANY REPRODUCTION IN PART OR AS A WHOLE WITHOUT THE WRITTEN PERMISSION OF RYADON INC. IS PROHIBITED.				
	THIRD ANGLE PROJECTION	SIZE	ENGR	SALES	QUALITY
		<b>A</b>	KCHEN		
			DATE	SCALE: 1:8	DO NOT SCALE

- NOTES:
1. DIMENSIONS APPLY AFTER FINISH.
  2. DO NOT SCALE DRAWING.
  3. BREAK ALL SHARP EDGES AND REMOVE ALL BURRS.
  4. MUST HAVE NO SCRATCHES, DINGS, DENTS OR SURFACE IMPERFECTIONS OTHER THAN SURFACE FINISH REQUIREMENTS.
  5. CRITICAL DIMENSIONS ARE INDICATED BY:
  6. TO BE INSPECTED TO 2.5 AQL SAMPLING PLAN UNLESS OTHERWISE STATED.
  7. ENSURE PACKAGING WILL PROVIDE ADEQUATE PROTECTION DURING TRANSPORT.
  8. GEOMETRIC FEATURES NOT DIMENSIONED ARE CONTROLLED BY 3D MODEL.