

HCL.

Column level indicators with U shaped protections

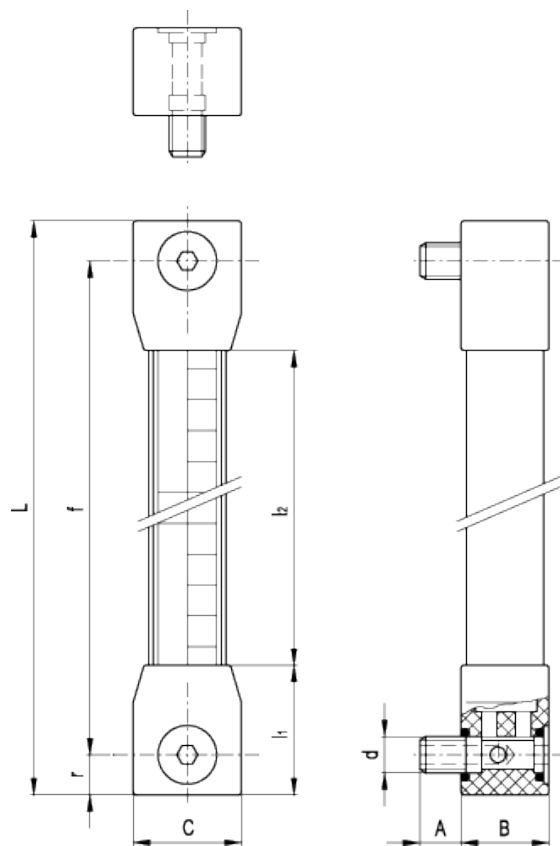

american unit
metric unit

Elesa Standards		Main dimensions									Weight
Code	Description	f	d	A	B	C	L	l ₁	l ₂	r	lbs g
111211	HCL-300-M12	11.81 300	- M12	0.53 13.5	1.12 28.5	1.38 35	12.83 326	1.65 42	9.53 242	0.51 13	0.5 227
111221	HCL-400-M12	15.75 400	- M12	0.53 13.5	1.12 28.5	1.38 35	16.77 426	1.65 42	13.46 342	0.51 13	0.59 268
111231	HCL-500-M12	19.69 500	- M12	0.53 13.5	1.12 28.5	1.38 35	20.71 526	1.65 42	17.4 442	0.51 13	0.674 306

Elesa Standards		Main dimensions									Weight
Code	Description	f	d	A	B	C	L	l ₁	l ₂	r	lbs g

Drilling template

Holes without burrs and chamfer

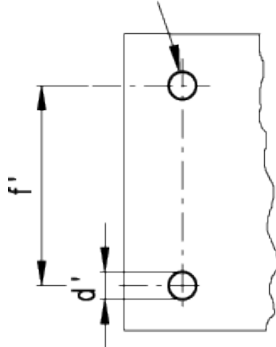

Drilling and installation data			
Description	d' _{-0.008}	f' _{±0.008}	Maximum tightening torque [ft·lbf] [Nm]
HCL-300	0.49 12.5	11.81 300	- 15
HCL-400	0.49 12.5	15.75 400	- 15
HCL-500	0.49 12.5	19.69 500	- 15

Material

Transparent tube with lenticular effect in acrylic material.

Protection

Aluminium in natural colour. It can be turned by 190°F (90°C) where necessary.

Assembly ends

Glass-fibre reinforced polyamide based (PA) technopolymer, black colour.

Screws

Zinc-plated steel with hexagon socket.

Packing ring

NBR synthetic rubber O-Ring.

Graduated contrast screen

Plastic material, resistant to oils and greases. Fitted to the aluminium protection by means of an adhesive tape.

Maximum continuous working temperature

160°F (70°C) (with oil or water).

Technical data

In laboratory tests carried out with mineral oil for hydraulic systems type CB68 (according to ISO 3498) with gradually increasing pressure, at 73°F (23°C), the weld stood up as follows:

- HCL.300 30 bar
- HCL.400 25 bar
- HCL.500 20 bar

In any case we suggest to verify the suitability of the product under the actual working conditions. If you need to use the indicator with other oils or fluids and under different pressure and temperature conditions, please contact ELESA Technical Department or carry out tests in order to guarantee a proper use.

Special executions on request (For sufficient quantities)

- Column level indicators with tubes and fixing endings in different materials to be used with special fluids and/or at high temperatures.
- AISI 316 stainless steel screws or nickel-plated brass.
- Polyamide based (PA) technopolymer float, red colour.
- Column level indicators with fitting centre-holes up to 0.079 (2,000 mm).
- HCL/E column oil level indicators including float, minimum level signal, normally closed contacts (N.C.), normally open (N.A.) or change over.
- Variable position level sensors which can be placed along the axis of the indicator, with right (DX) or left (SX) connectors, normally closed (N.C.), normally open (N.A.) or change over contacts.
- Packing rings in FKM (VITON® type, registered trademark of DuPont Dow Elastomers) or in EPDM.