

SPR.V

Guide rail brackets for linear and angular positioning

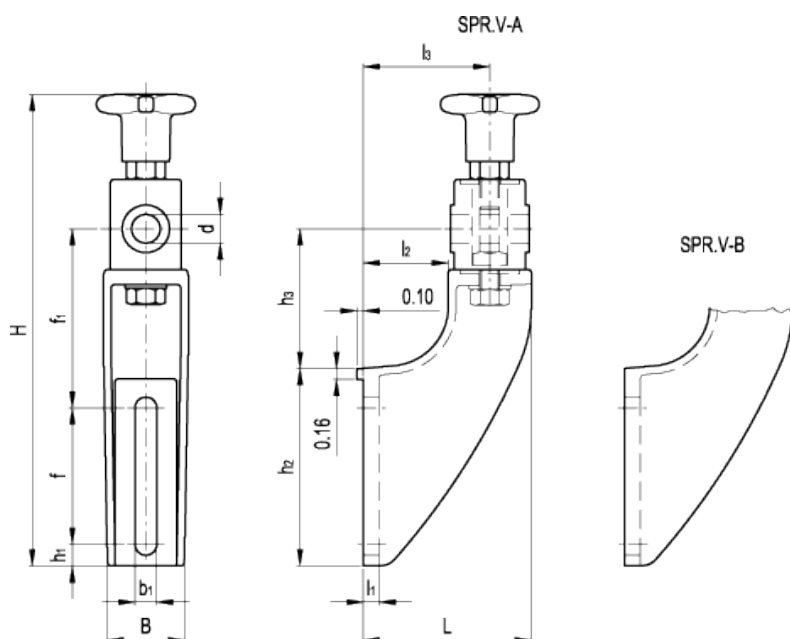

american unit
metric unit

Elesa Standards		Main dimensions											Guide assembly hole	Weight	
Code	Description	H	L	B	f	f ₁	b ₁	h ₁	h ₂	h ₃	l ₁	l ₂	l ₃	d	lbs g
419755	SPR.V-12-A	7.99 203	2.76 70	1.46 37	1.65 42	3.07 78	0.43 11	0.59 15	2.99 76	2.36 60	0.31 8	1.18 30	1.97 50	0.47 12	0.562 255
419756	SPR.V-14-A	7.99 203	2.76 70	1.46 37	1.65 42	3.07 78	0.43 11	0.59 15	2.99 76	2.36 60	0.31 8	1.18 30	1.97 50	0.55 14	0.551 250
419757	SPR.V-16-A	7.99 203	2.76 70	1.46 37	1.65 42	3.07 78	0.43 11	0.59 15	2.99 76	2.36 60	0.31 8	1.18 30	1.97 50	0.63 16	0.54 245
419658	SPR.V-12-B	9.37 238	3.35 85	1.61 41	2.72 69	3.54 90	0.43 11	0.43 11	3.94 100	2.76 70	0.31 8	1.69 43	2.52 64	0.47 12	0.595 270
419659	SPR.V-14-B	9.37 238	3.35 85	1.61 41	2.72 69	3.54 90	0.43 11	0.43 11	3.94 100	2.76 70	0.31 8	1.69 43	2.52 64	0.55 14	0.584 265
419660	SPR.V-16-B	9.37 238	3.35 85	1.61 41	2.72 69	3.54 90	0.43 11	0.43 11	3.94 100	2.76 70	0.31 8	1.69 43	2.52 64	0.63 16	0.573 260

Elesa Standards		Main dimensions											Guide assembly hole	Weight	
Code	Description	H	L	B	f	f ₁	b ₁	h ₁	h ₂	h ₃	l ₁	l ₂	l ₃	d	lbs g

Bracket

Glass-fibre reinforced polyamide based (PA) technopolymer. Resistant to solvents, oils, greases and other chemical agents. Hole for clamping system assembly.

Colour

Black, matte finish.

Guide rail cylinder

Glass-fibre reinforced technopolymer. Black colour, matte finish.

Clamping system

- Nickel-plated AISI 431 stainless steel eye screw.
- Glass-fibre reinforced technopolymer clamping knob, black colour, matte finish. Nickel-plated brass insert with tapped hole and hexagonal end.
- Nut, screw and washer for the fixing of guide rail cylinder in AISI 304 stainless steel.

Special executions on request (For sufficient quantities)

AISI 304 stainless steel guide rail cylinder.

Features and applications

SPR.V guide rail brackets are particularly suitable when the angular and linear positioning needs to be executed in different moments, for example when the distance between the guides has to be set more frequently than the angulation.

Assembly instructions

- Fit the guide rail bracket (Fig. 1).
- Assemble the guide rail cylinder to the support, with screw, nut and washer (Fig. 2).
- Insert the washer on the eye screw and assemble the knob (Fig. 3).
- Insert the eye in the guide rail cylinder housing (Fig. 4).
- Insert the guide pin in the guide rail cylinder hole. Set its linear and angular position and then clamp the knob (linear positioning) and the fixing nut of guide rail cylinder (angular positioning) (Fig. 5).

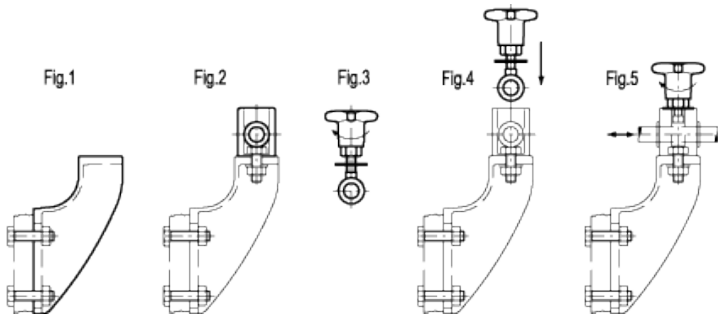

Accessories on request

Spacer for guide rail bracket DSG-A (code 419676) or DSG-B (code 419677) in glass-fibre reinforced technopolymer, black colour, matte finish.

