

GN 618

Indexing plungers

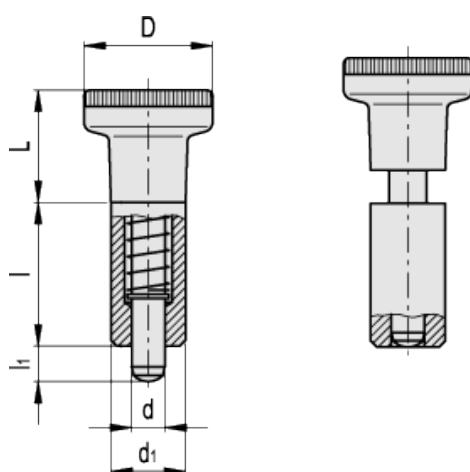

Elesa-Gantergriff		Main dimensions						Spring pressure		Weight
Code	Description	$d^{-0.02-0.04}$	L	$d_{1\ h9}$	D	l	$l_{1\ min.}$	Preload [N~]	Max. load [N~]	g
GN.36101	GN 618-5-A	5	18	12	21	22	5	7	17	30
GN.36111	GN 618-6-A	6	22.5	14	25	26	6	9	24	44
GN.36121	GN 618-8-A	8	27	18	31	34	8	12	30	44

Plain body
Black-oxide steel, welding quality.

Plunger
Black-oxide steel with hardened end.
Suggested tolerance for matching hole = G7.

Knob
High-resilience polyamide based (PA) technopolymer, black colour, matte finish. Resistant to solvents, oils, greases and other chemical agents.

Features and applications
GN 618 indexing plungers are especially designed for assembly by means of welding.