

C-Style Product Overview

Features:

Operation is very simple. The operator slides the spring loaded moveable jaw toward the workpiece to the nearest notch where it locks into the detent. Hand tightening the screw advances the clamp jaw. The jaw advances the tilting pad directly into contact with the workpiece – there is no rotating to twist the work or the clamp out of position.

An unusual and very useful feature of these clamps is the ability to use the clamp for spreading or locating as well as squeezing..

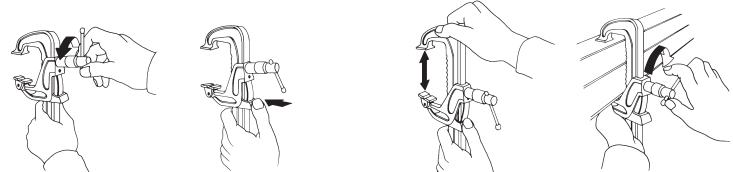

1. Loosen Screw 2. Push In Jaw Base 3. Slide Jaw Up or Down 4. Tighten Screw

C-Style Technical Information, Holding Capacities

Holding Capacity	Throat Depth B1 [in] mm	Width Opening S [in] mm	Model	Clamping Screw Ø	Weight [lbs.] kg	Consisting of:	
						1 x	1 x
 [2,500 lbf] 11300N	[2.38] 60	[0-6] 150 [0-12] 300 [0-20] 500	T186-6 T186-12 T186-20	M12	[2.75] 1,4 [3.75] 1,8 [5.51] 2,5	186-6-1 186-12-1 186-20-1	186-2 186-2 186-2
 [1,270 lbf] 5650N	[4.7] 120	[0-10] 250	T321-10	M12	[4.4] 2,0	321-10-1	321-2
 [4,000 lbf] 18000N	[3.5] 90	[0-9] 225 [0-18] 450 [0-40] 1000	T290-9 T290-18 T290-40	M16	[10.00] 5,5 [13.50] 7,0 [23.15] 10,5	290-9-1 290-18-1 290-40-1	290-2 290-2 290-2 290-2
 [2,000 lbf] 9000N	[8.0] 200	[0-9] 225 [0-18] 450	T285-9 T285-18	M16	[12.00] 7,1 [13.50] 8,5	285-9-1 285-18-1	285-2 285-2
 [6,000 lbf] 27000N	[4.5] 115	0-24 0-36	T257-24 T257-36	M20	[27.50] 13,1 [32.50] 15,8	257-24-1 257-36-1	257-2 257-2

ⓘ Available upon request

C-Style Technical Information, Holding Capacities, Standard Clamp Dimensions

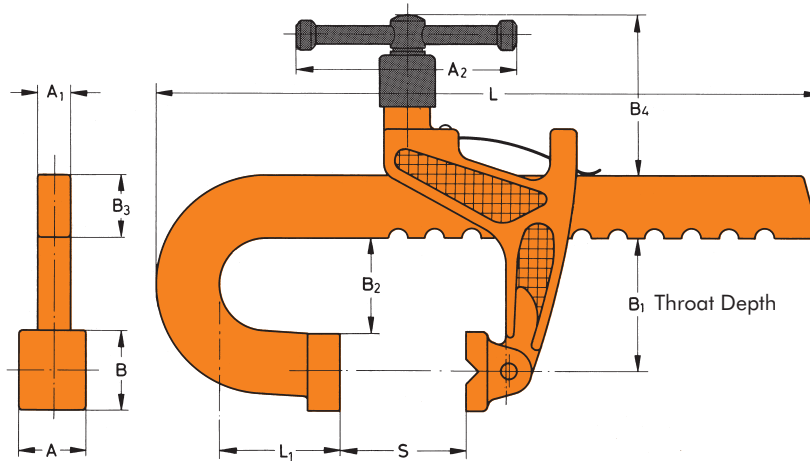

Model	[inch] mm									
	A	A1	A2	B	B2	B3	B4	L	L1	
T186-6				[1.26] 32		[1.30] 33		[9.65] 245	[.79] 20	
T186-12	[0.98] 25	[0.51] 13	[3.00] 76	[1.26] 38	[1.69] 43	[1.30] 33	[3.00] 76	[15.55] 395	[.79] 20	
① T186-20				[1.38] 35		[1.18] 30		[24.61] 625	[1.18] 30	
T321-10	[0.98] 25	[0.51] 13	[3.00] 76	[1.38] 35	[4.02] 102	[1.32] 33,5	[3.00] 76	[14.2] 360	[1.00] 25	
T290-9								[16.53] 420		
T290-18	[1.57] 40	[0.79] 20	[5.51] 140	[2.36] 60	[2.56] 65	[1.57] 40	[4.13] 105	[25.78] 655	[2.56] 65	
① T290-40								[47.44] 1205		
T285-9								[16.53] 420		
T285-18	[1.57] 40	[0.79] 20	[5.51] 140	[2.36] 60	[7.09] 180	[1.57] 40	[4.13] 105	[25.78] 655	[2.56] 65	
T257-24								[33.46] 850		
T257-36	[2.00] 51	[0.87] 22	[7.36] 187	[2.36] 60	[3.35] 85	[2.00] 51	[5.00] 127	[45.87] 1165	[3.94] 100	

① Available upon request