

# EBP.SAN

Bridge handle with antimicrobial protection (front mounting)

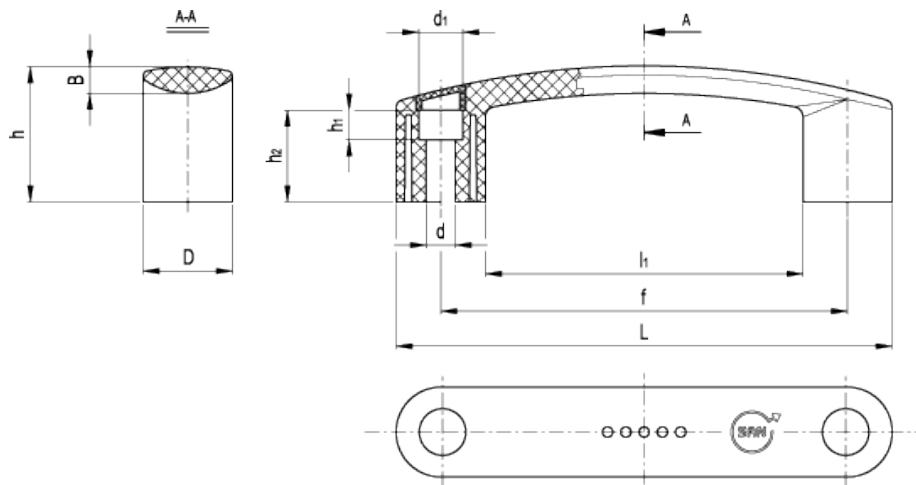

american unit  
metric unit

Elesa Standards		Main dimensions						Mounting holes				F <sub>1</sub>	F <sub>2</sub>	L <sub>1</sub>	L <sub>2</sub>	Weight
Code	Description	L	f	D	h	B	l <sub>1</sub>	d	d <sub>1</sub>	h <sub>1</sub>	h <sub>2</sub>	[lbf] [N]	[lbf] [N]	[ft·lb] [J]	[ft·lb] [J]	lbs g
153211-C1	EBP.140-8-SAN-C1	5.67 144	4.61±0.02 117±0.5	1.02 26	1.54 39	0.33 8.5	3.62 92	0.33 8.5	0.53 13.5	0.33 8.5	1.04 26.5	605 2700	403 1800	7 10	3 4	0.121 55

## Material

Glass-fibre reinforced polyamide based (PA) technopolymer with silver ions on an inorganic ceramic base. Resistant to solvents, oils, greases and other chemical agents.

## Colour

Black, matte finish.

## Caps

Technopolymer, black colour, matte finish, supplied not assembled, press-fit assembly, removable by a screwdriver.

## Assembly

Through holes for cylindrical-head screws with hexagon socket.

## Features

The special antimicrobial material EBP.SAN is made out of, stops any deposit of bacteria, mildew and fungi, offering a sanitized effect on the surface.

Tests carried out on material samples confirmed the stability of the antimicrobial action after several cleaning cycles at high temperatures with soap and solvents.

The great resistance to high temperatures of the antimicrobial additive allows this handle to reach sterilisation temperatures 270°F (130°C).

## Applications

EBP.SAN handle is suitable for applications where hygienic and sanitary elements are required:

- medical and hospital equipment
- disability aids
- machines for food processing and pharmaceutical industry
- equipment for catering service
- urban and public fittings.

*Technical data*

Tensile stress and impact strength: F1, F2, L1 and L2 values reported in the table are the result of breaking tests carried out with the appropriate dynamometric equipment under the test conditions shown in the figure with ambient temperature.

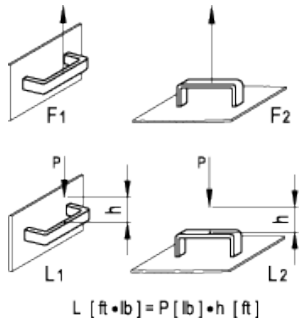

STANDARD MACHINE ELEMENTS WORLDWIDE

ELESA models all rights reserved in accordance with the law. Always mention the source when reproducing our drawings.